

## Pro-8 Universal Industrial Controller

BluePort Front interface and BlueControl software

Maintenance manager and error list

Start-up circuit and boost function

Two switchable parametersets

Self-tuning to the setpoint without oscillation

Monitoring of heating current and output circuit

3-point controller for water, fan and oil cooling

- Universal continuous/switching version, i.e. reduced stocks
- 100 ms cycle time, i.e. also suitable for fast control loops
- 20ms as shortest pulse for very fast / strong actuators (e.g. infrared heater or water cooling)
- Freely configurable analog output, e.g. as process value output
- Customer-specific linearization for all sensors
- Settings can be blocked via password and internal switch for high security
- Extended temperature range up to 60 °C allows mounting close to the process
- Easy 2-point or offset measurement correction
- Emergency operation after sensor break by means of the "output hold" function
- Logical combination of digital outputs, e.g. for general alarm
- Programmer with 10 segments and "end" signal
- RS 422/485 Modbus RTU interface
- Built-in transmitter power supply
- Splash-water proof front (IP 65)

require oscillation, and performs a minimal deviation of the process value.

Display and operation

Clear information are given by ten indicator LEDs in the front panel that display operating mode, I/O states, and errors. The automatic/manual-key switches the controller into the manual mode directly. If required, the direct switch over can be disabled or the key can be configured e.g. reset the latched alarms.

By the flexibly applicable function key an external switch can be omitted in many cases, because one can start now e.g. the boost function directly.

Front interface and Engineering Tools

Control parameter adjustment in seconds has now also been implemented in the Pro-8 class of instruments.

Via the BlueControl software incl. its simulation functions, and especially the convenient BluePort front panel interface, the required set-up for a specific control task can be determined without a detailed study of the operating instructions.

Of course almost all adjustments can be done comfortably over the instrument front. (see page 7, BlueControl)

Password protection

If required, the various operating levels can be protected with a password to prevent unauthorized access.

### DESCRIPTION

These universal temperature controllers are intended for precise, and cost-effective control tasks in all branches of industry. For this, the unit provides simple 2-point (on/off) control, continuous PID control, or 3-point stepping control. The process value signal is connected via a universal input. A supplementary analog input can be used for heating current measurement or as an external set-point input. All these controllers have at least three process outputs that can be 3 relays or 2 relays plus a universal output. This universal output can be used for operating a solid-state relay, a continuous current/voltage output or to energize a two-wire transmitter. Optionally there are two additional opto coupler outputs, that can be used freely.

The selectable function "start-up" ensures increased lifetime of high-performance electrical heating elements (e.g. hot runner moulds).

Plug-in module

Pro-8 controllers are built as plug-in modules. This enables them to be replaced very quickly without tools, and without disturbing the wiring.

Self-tuning during start-up and to the setpoint

This new function determines the optimum settings for fast line-out without overshoot. With three-point controller configuration, the "cooling" parameters are determined separately, thus ensuring an optimum match to the process.

By pushing a button the controller determines the best control parameters at the actual setpoint. This function does not

### APPLICATIONS

- › Furnaces and ovens
- › Burners and boilers
- › Plastics processing
- › Hot runners
- › Driers
- › Climatic chambers
- › Heat treatment plants

TECHNICAL DATA

INPUTS

SURVEY OF THE INPUTS

Input	Used for
INP1	x (process value)
INP2	Heating current, ext. set-point
d1	Operation disabled, switch-over to second set-point SP.2 external set-point S.P.E, fixed correcting variable Y2, manual operation, controller off, disable auto/manual function, reset of stored alarms, boost, parameter set 1 ↔ 2
d2 (option)	
d3 (option)	

PROCESS VALUE INPUT INP1

EResolution: > 14 bit  
 Decimal point: 0 to 3 decimals  
 Digital input filter: adjustable 0,000...9999 s  
 Scanning cycle: 100 ms  
 Measured value correction: 2-point or offset correction  
 Thermocouples (Table 1)  
 Internal and external temperature compensation  
 Input impedance: ≥1 MΩ  
 Effect of source resistance: 1 μV/Ω

Cold junction compensation  
 Max. additional error ± 0,5 K  
 Sensor break monitoring  
 Sensor current: 1 μA  
 Operating sense configurable (see page 4)

Resistance thermometer  
 Connection: 3-wire  
 Lead resistance: max. 30 Ω  
 Input circuit monitor: Break and short circuit

Special measuring range  
 The BlueControl software can be used to match the input to the sensor KTY 11-6 (characteristic is stored in the controller).  
 Physical measuring range: 0...4500 W  
 Linearization segments: 16

Dimensions (mm):

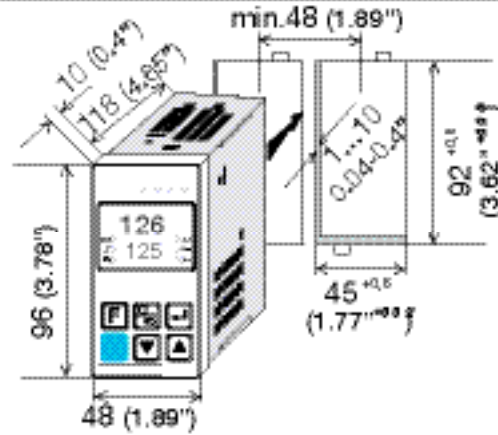

Electrical connections (part 1): All except KS50-1\_4-00\_ -

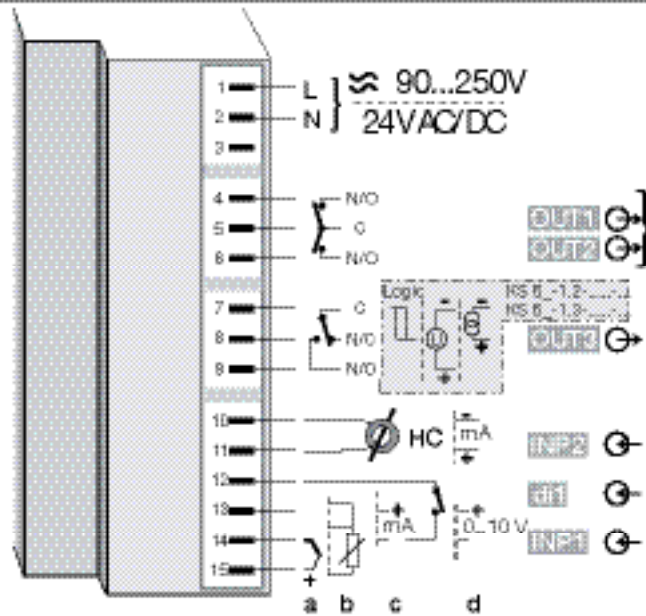

Electrical connections (part 2): KS50-1\_4-00\_ - only

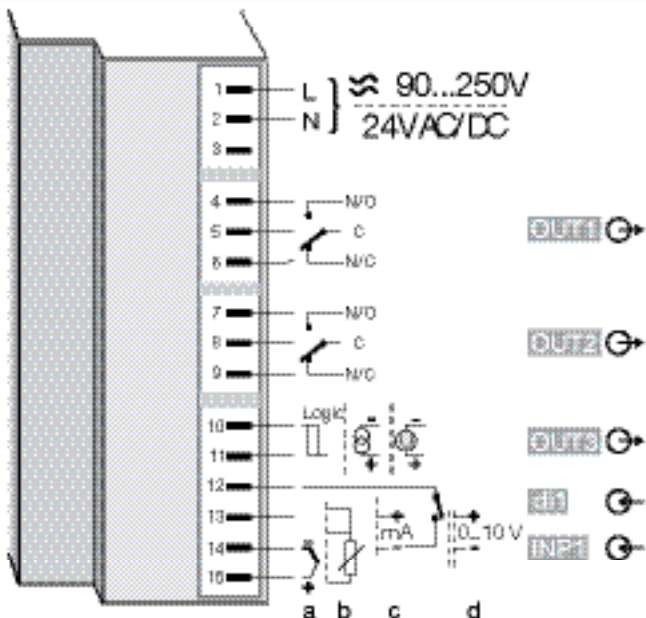



**GALVANIC ISOLATIONS**

- Safety isolation
  - Functional isolation
- Pro-8  
(di2 and di3 24V inputs)

Mains supply	Process value INP1 Supplementary input INP2 Digital input di1
Relay outputs OUT1,2	RS 422/485 interface
Relay outputs OUT3	Digital inputs di2, 3
	Universal output OUT3 Transmitter supply UT
	OUT5, OUT6

Pro-8 (di2 and di3 24V contact inputs)

**RELAY OUTPUTS OUT1, OUT2**

- Contacts: 2 NO contacts with common connection
- Max. contact rating: 500 VA, 250 VAC, 2A at 48...62 Hz, resistive load
- Min. contact rating: 6 V, 1 mA AC/DC
- Duty cycle electric: for I = 1A/2A: ≥ 800,000 / 500,000 (at ~250V / (resistive load))

**OUT3 USED AS RELAY OUTPUT**

- Contacts: Potential-free changeover contact
- Max. contact rating: 500 VA, 250 VAC, 2A at 48...62 Hz, resistive load
- Min. contact rating: 5 V, 10 mA AC/DC
- Duty cycle electric: for I = 1A/2A: ≥ 1,000,000 / 600,000 (at ~250V / (resistive load))

Note:  
If the relays OUT1...OUT3 operate external contactors, these must be fitted with RC snubber circuits to manufacturer specifications to prevent excessive switch-off voltage peaks.

**Example of the linkage of the internal functions:**

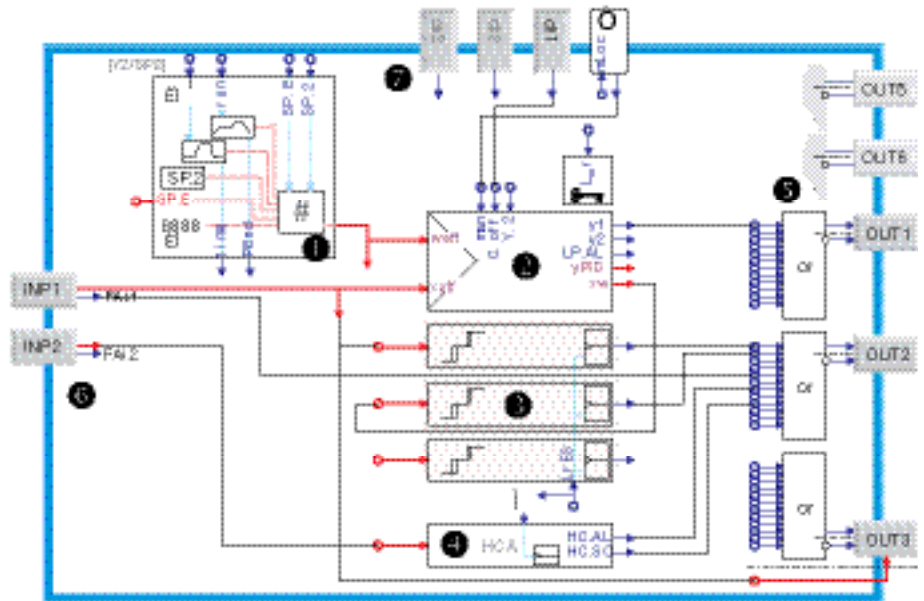

- ❶ setpoint processing with programmer, boost function and start-up circuit
- ❷ controller function with loop monitoring
- ❸ limit monitoring, configurable with latch and suppression
- ❹ heating current monitoring
- ❺ output processing with logic or-combination and inverting
- ❻ analog inputs with logical sensor fail signal

**Modbus Master function supports setpoint changes e.g. in extruder applications**

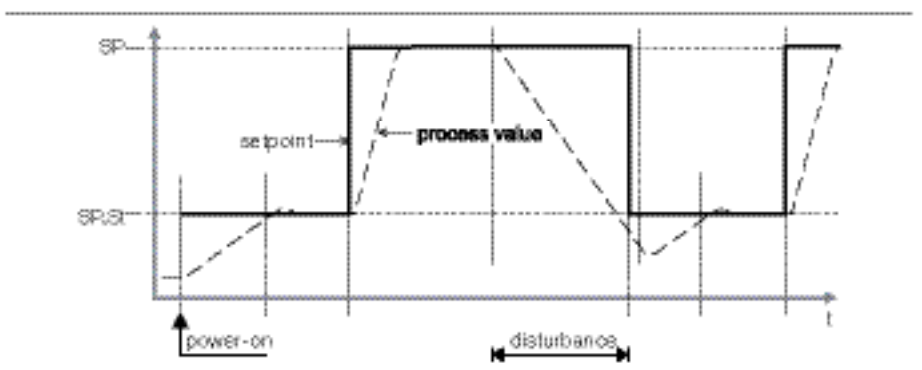
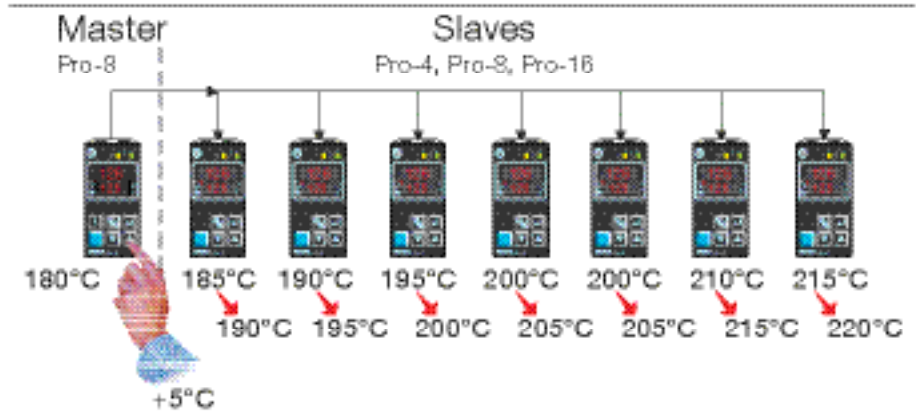

**Start-up circuit**

When the process is controlled towards the start-up set-point, the output value is limited. The start-up set-point is kept constant during the start-up holding time. After that, the main setpoint SP is controlled. If a disturbance reduced the process value, the start-up circuit is activated again.

## OUT3 AS UNIVERSAL OUTPUT

Galvanically isolated from the inputs.

Freely scalable

Resolution: 11 bit

Time constant of the

AD-converter T90: 50 ms

Limit frequency of the

whole continuous controller: > 2 Hz

Current output

0/4...20 mA, configurable.

Signal range: 0...approx. 22 mA

Load: ≤ 500 W

Load effect: none

Resolution: ≤ 22 mA (0,1%)

Error: ≤ 40 mA (0,2%)

Voltage output

0/2...10V, configurable

Signal range: 0...11 V

Load: ≥ 2 kΩ

Load effect: none

Resolution: ≤ 11 mV (0,1%)

Error: ≤ 20 mV (0,2%)

OUT3 as transmitter supply

Output: 22 mA / 3 13 V

OUT3 as logic output

Load ≤ 500 Ω 0/≤ 20 mA

Load > 500 Ω 0/> 13 V

## OUTPUTS OUT5, OUT6 (OPTIONAL)

Galvanically isolated opto-coupler outputs.

Grounded load:  
common positive control voltage.

Output rating: 18...32 VDC; =70 mA Internal

voltage drop: =1 V with I max Protective

circuit: built-in against short circuit, reversed polarity.

Note: For inductive load a free-wheel diode has to be connected external

## FUNCTIONS

### CONTROL BEHAVIOUR

- Signaler with adjustable switching differential (ON/OFF controller)
- PID controller (2-point and continuous)
- Delta / Star / Off or 2-point controller with switch over from partial to full load
- 2 x PID (heating/cooling)
- 3-point stepping controller

Two parameter sets for manual gain scheduling

Self-tuning control parameters or adjustable manually via front keys or BlueControl software.

### BEHAVIOUR WITH 2- AND 3-POINT CONTROLLERS

## Display and operation

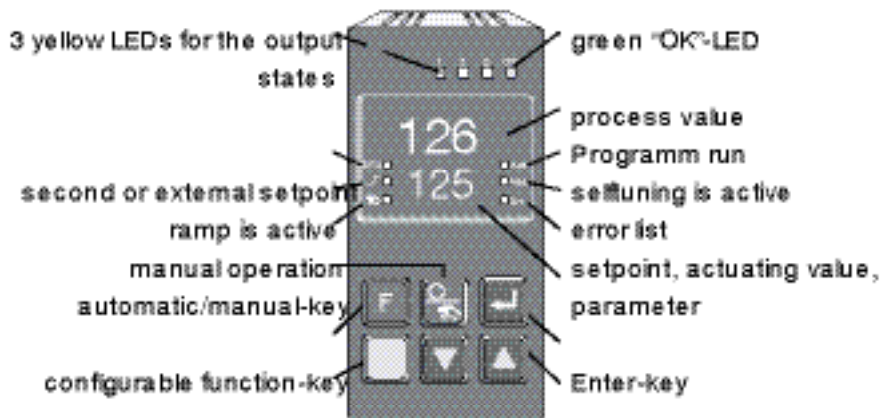

- Standard behaviour:  
For precise matching of the required output value at the output signal limits, the controller changes the cycle times for heating and cooling automatically and continuously.
- With constant cycle times:  
The length of the shortest heating and cooling pulse is adjustable.
- Water cooling linear (heating=standard):  
To ensure a sufficient cooling effect, the cooling function starts only after reaching an adjustable temperature value. The pulse length is adjustable, too and remains constant for all output values.
- Water cooling nonlinear (heating=standard):  
The general function is described above but the controller additionally takes in consideration that the water cooling is usually much stronger than the heating (thus preventing undesirable behavior when changing from heating to cooling).

### SET-POINT FUNCTIONS

- Adjustable set-point gradient
- 0,01...9999 °C/min
- Set-point control
- Set-point/cascade control
- Program controller with 4 segments (set-point/section time)

### BEHAVIOUR WITH SENSOR BREAK OR SHORT CIRCUIT:

- Control outputs switched off
- Switch-over to a safe output value
- Switch-over to a mean output value
- (PID controller)

Flashing Error LED indicates active alarm in the error list:



## SPECIAL FUNCTIONS

### BOOST FUNCTION

The boost function provides a short-term increase of the set-point, e.g. with hot runner control, in order to clear nozzles of "frozen" rests of material.

### START-UP CIRCUIT

For temperature control, e.g. with hot runners. High-performance heating elements with magnesium oxide insulation must be heated slowly, to remove any humidity and to prevent destruction.

### MODBUS MASTER

The Pro-8 can be configured as Modbus Master.

This enables it to transmit user-specified signals or parameters cyclically to all connected Slave controllers.

For example, the following applications are possible:

- Set-point shifting relative to the set-point adjusted in the Slave (see picture)
- matching of control parameters, limit contacts, etc.
- Limiting the output value (override control OVC)

### LIMIT SIGNALLING FUNCTIONS

Max., Min. or Max./Min. monitoring with adjustable hysteresis.

## FUNCTIONS

- Input signal monitoring
- Input signal monitoring with latch (reset via front key or digital input)

Several limit signals or alarms can be OR-linked before being output.

Applications: Release of a brake with motor actuators, general alarms, etc.

## ALARMS

Heating current alarm

- Overload and short circuit
- Open circuit and short circuit

Limit value adjustable 0...9999 A

Control loop alarm

Automatic detection if there is no response of the process to a change of output value.

Sensor break or short circuit

Depending on selected input type, the input signal is monitored for break and short circuit.

## MAINTENANCE MANAGER

Display of error signals, warnings, and latched limit messages in the error list. Signals are latched, and can be reset manually.

Possible signals in the error list:

Sensor break, short circuit, reversed polarity
Heating current alarm
Control loop alarm
Fault during self-tuning
latched limit messages
e.g. re-calibration warning (If the adjusted operating hours are exceeded a message is displayed)
e.g. maintenance interval of actuator (If the adjusted switching cycles are exceeded a message is displayed)
Internal fault (RAM, EEPROM, ...)

## OPERATION AND DISPLAY

Display



process value: LED with 7 segments  
10,5 mm

lower display: LED with 7 segments  
7,8 mm

text display: 8-character dot matrix used for displaying e.g. the programme status

Operating functions

The functions of the  $\hat{O}$ -key are configurable:

Function		
Remote (no front operation)		X
SP.2 (2nd setpoint)		X
Y.2 (2nd output value)	X	X
SPE (external setpoint)	X	X
Manual operation	X	X
C.OFF (controller function off)	X	X
Lock of manual key		X
Reset of latched limits and error list	X	X
Boost		X
Parameter set 1/2		X
Programmer run/stop		X

Several functions can be combined e.g. SP.2 and parameter set switch-over (gain scheduling) with only one key.

## POWER SUPPLY

Depending on version:

AC SUPPLY

Voltage: 90...260 VAC  
Frequency: 48...62 Hz  
Power consumption: approx. 7 VA

UNIVERSAL SUPPLY 24 V UC

AC voltage: 20,4...26,4 VAC  
Frequency: 48...62 Hz  
DC voltage: 18...31 V DC  
Power consumption: approx. 8 VA (W)

BEHAVIOUR WITH POWER FAILURE

Configuration, parameters, and adjusted set-points, control mode:

Non-volatile storage in EEPROM

## BLUEPORT® FRONT INTERFACE

Connection of PC via PC adapter (see "Accessories"). The BlueControl software is used to configure, set parameters, and operate the Pro-8.

## BUS INTERFACE (OPTION)

RS 422/485 INTERFACE

Galvanically isolated

Physical: RS 422/485  
Protocol: Modbus RTU  
Transmission speed: 2400, 4800, 9600, 19.200 bits/s

Address range: 00...99

Number of controllers per bus: 32

Repeaters must be used to connect more controllers.

## ENVIRONMENTAL CONDITIONS

Protection modes

Front panel: IP 65 (NEMA 4X)  
Housing: IP 20  
Terminals: IP 00

Permissible temperatures

For specified accuracy: 0...60°C  
Warm-up time: < 15 minutes  
Temperature effect: < 100p pm/K  
For operation: -20...65°C  
For storage: -40...70°C

Humidity

75% yearly average, no condensation

Shock and vibration

Vibration test Fc (DIN 68-2-6)

Frequency: 10...150 Hz  
Unit in operation: 1g or 0,075 mm  
Unit not in operation: 2g or 0,15 mm

Shock test EA (DIN 68-2-27)

Shock: 15g  
Duration: 11ms

Electromagnetic compatibility

Complies with EN 61 326-1

- Complies with the immunity requirements for continuous, unattended operation
- Complies with the emission requirements class B for rural areas
- Surge disturbances may increase the measurement error and lead to error messages

**GENERAL**

Housing

Material: Makrolon 9415, flame-retardant

Flammability class: UL 94 VO, self-extinguishing

Plug-in module, inserted from the front

Safety tests

Complies with EN 61010-1 (VDE0411-1): Over voltage category II

Contamination class 2

Working voltage range 300 VAC

Protection class II

Certifications

Type tested to EN 14597 (replaces DIN 3440)

With certified sensors applicable for:

- Heat generating plants with outflow temperatures up to 120°C to DIN 4751
- Hot-water plants with outflow temperatures above 110°C to DIN 4752
- Thermal transfer plants with organic transfer media to DIN 4754
- Oil-heated plants to DIN 4755

CULus-certification

(Front Panel-mounted Type1, indoor use)

GOST-R Certificate: (on request)

For each shipment to the Russian Federation and GUS-states, an authenticated certificate is to be delivered with the GOST-R certificated controllers (Pro-4, Pro-8, Pro-16, one certificate per shipment - 9499-047-14465).

Electrical connections

Depending on version:

- Flat-pin connectors 1 x 6,3 mm or 2 x 2,8 mm to DIN 46 244
- Screw terminals for conductor cross-section from 0,5 to 2,5 mm<sup>2</sup>

For device with screw terminals the length of the removed insulation must be at least 12mm. The cable end sleeve must be chosen accordingly.

Mounting

Panel mounting with two fixing clamps at top/bottom or left/right

Close mounting possible

Mounting position: not critical

Weight: 0,27 kg (9.52 oz)

Accessories supplied with unit

Operating instructions

2 fixing clamps

**BlueControl, versions and functionality:**

Functionality	Mini	Basic	Expert
parameter and configuration setting	yes	yes	yes
controller and loop simulation	yes	yes	yes
download: transfer of an engineering to the controller	yes	yes	yes
online mode / visualization	SIM only	yes	yes
defining an application specific linearization	yes	yes	yes
configuration in the extended operating level	yes	yes	yes
upload: reading an engineering from the controller	SIM only	yes	yes
basic diagnostic functions	no	no	yes
saving data file and engineering	no	yes	yes
printer function	no	yes	yes
online documentation, help	yes	yes	yes
implementation of measurement value correction	yes	yes	yes
data acquisition and trend display	SIM only	yes	yes
wizard function	yes	yes	yes
extended simulation	no	no	yes
customer-specific default data-set	no	no	yes
programeditor (KS 90-1 programmer only)	no	no	yes

**ACCESSORY EQUIPMENT**

BlueControl (Engineering Tool)

PC-based programme for configuring, setting parameters, and operating (commissioning) the KS 9x-1 programmer. Moreover, all the settings are saved, and can be printed on demand.

Depending on version, a powerful data acquisition module is available, complete with trend graphics.

Visibility mask

The BlueControl software can be used to blind out parameters in the instrument. Thus, only allowed parameters can be changed on site.

Safety relevant parameters are invisible!

Two parameters are blinded out:

Name	Description	Visible
<b>Setp</b>	<b>Setpoint</b>	<input checked="" type="checkbox"/>
SP.LD	lower setpoint range	<input type="checkbox"/>
SP.Hi	upper setpoint range	<input type="checkbox"/>
SP.2	2nd setpoint	<input checked="" type="checkbox"/>
r.SP	setpoint ramp [/min]	<input checked="" type="checkbox"/>
t.SP	timer dwell time [min]	<input checked="" type="checkbox"/>

Simulation

The built-in simulation serves to test the controller settings, but can also be used for general training and observing the interaction between controller and control loop.

**SOFTWARE REQUIREMENTS**

Windows 95/98/NT/2000.

Configurations that can only be implemented via the BlueControl software (not via the front-panel keys):

- Customer-specific linearizations
- Enable “forcing” for inputs/outputs. Forcing allows to write the analog and digital inputs and outputs via Modbus interface.
- Adjustment of limits for operating hours and switching cycles
- Switch-over to 60 Hz mains frequency
- Master/slave configuration
- Disable operator actions and operating levels, plus password definition
- Prevent automatic optimization of cycle times T1, T2

**HARDWARE REQUIREMENTS**

A PC adapter (see “Accessories”) is required for connecting the controller. Updates and demo software can be downloaded from: [www.West-CS.com](http://www.West-CS.com)

ORDERING INFORMATION



KS 50-1 Format 48 x96	0
Flat-pin connectors	0
Screwterminals	1
90..250VAC, INP2, 3 relays	0
24VAC/ 18..30VDC, INP2, 3 relays	1
90..250VAC, INP2, 2 relays+ mA/V/ logic	2
24VAC/ 18..30VDC, INP2, 2 relays+mA/V/logic	3
90..250VAC, 2 relays (Wechsler)+mA/V/logic	4
no option	0
Modbus RTU+U +di2/3 +OUT5/6	1
U +di2/3 +OUT5/6	8
Standard configuration	0
Configuration to specification	9
No manual	0
Manual english	E

ACCESSORIES

Description		Order no.
Current converter 50A AC		9404-407-50001
PC adapter, for connecting the BlueControl software to the BluePort®		9407-998-00003
Standard rail adapter		9407-998-00061
Operating manual	English	9499-040-94011
Datasheet	English	9498-737-62613
BlueControl Mini	English	www.west-cs.com
BlueControl Basic	English	9407-999-11001
BlueControl Expert	English	9407-999-11011
BlueControl Universal	English	9407-999-19011

**Contact:**  
**Industrial Process Measurement, Inc.**  
**3910 Park Avenue, Unit 7**  
**Edison, NJ 08820**  
**732-632-6400**  
**support@instrumentation2000.com**  
**http://www.instrumentation2000.com**