

VAISALA

Vaisala HUMICAP® Hand-Held Humidity and Temperature Meter HM40



The HM40 Humidity Meter can be chosen either in standard or remote probe version.

The HM40 is a compact and portable humidity meter at hand everywhere you go. It is an ideal spotchecking tool that is easy to use and provides reliable measurement. It can be used for a wide range of various portable measurement applications. According to a user's needs, the meter is available in two models: standard and with a remote probe.

Simple and easy to use

The HM40 includes a user-friendly, large graphical display and easy-to-use push buttons. The user interface is simple and intuitive to use, and available in 10 languages. Also, many other settings can be modified by the user to best suit his individual needs. In addition to relative humidity and temperature, the HM40 provides five calculated humidity parameters,

all available in both metric and nonmetric units.

The meter is powered by 2 AA-sized batteries. An external NiMH battery recharger with USB connection and rechargeable NiMH batteries are offered as an option. Each HM40 comes also with a handy belt clip and a case.

Easy recalibration

The calibration of the HM40 is easy: just send the meter back to a Vaisala Service Center for recalibration or simply plug in a recently calibrated interchangeable HMP113 measurement probe. Alternatively, the HM40 can be user calibrated on site using a humidity reference, e.g. the Vaisala Humidity Calibrator HMK15.

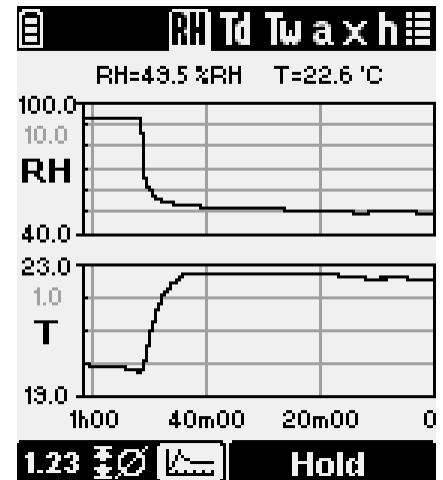

The graph clearly indicates when the readings have stabilized.

Benefits

- Compact and portable, easy to use hand-held meter
- Versatile meter with wide measurement range and multiple calculated parameters
- Standard and remote probe models available
- Ideal for spot-checking, on the go

Features

- Humidity measurement range 0 ... 100 %RH
- Operating temperature range -10 °C ... +60 °C
- Incorporates the proven Vaisala HUMICAP® 180R Sensor
- The interchangeable measurement probe HMP113 can be user calibrated
- Graphical display indicates when measurement has stabilized
- Hold-button to freeze the screen and save the reading
- Multilingual user interface with 10 languages (EN, DE, FR, JA, ZH, PT, ES, RU, FI, SV)

Technical Data

Performance

| | |
|---|--|
| RELATIVE HUMIDITY | |
| Measurement range | 0 ... 100 %RH |
| Accuracy (including non-linearity, hysteresis, and repeatability): | |
| at 0 ... +40 °C (+32 ... +104 °F) | ±1.5 %RH (0 ... 90 %RH) ±2.5 %RH (90 ... 100 %RH) |
| at -10 ... 0 °C and +40 ... +60 °C (+14 ... +32 °F and +104 ... +140 °F) | ±3.0 %RH (0 ... 90 %RH) ±4.0 %RH (90 ... 100 %RH) |
| Factory calibration uncertainty | |
| at +20 °C (+68 °F) | ±1.5 %RH |
| Humidity measurement response time (90%) with plastic grid filter | 17 s |
| Stability | ±2 %RH over 2 years |
| Humidity sensor | HUMICAP® 180R |
| TEMPERATURE | |
| Measurement range | -10 ... +60 °C (14 ... 140 °F) |
| Accuracy over temperature range: | |
| at 0 ... +40 °C (+32 ... +104 °F) | ±0.2 °C (0.36 °F) |
| at -10 ... 0 °C and +40 ... +60 °C (+14 ... 32 °F and +104 ... +140 °F) | ±0.4 °C (0.72 °F) |
| Temperature sensor | Pt1000 RTD Class F0.1 IEC 60751 |

Mechanics

| | |
|----------------------------------|--|
| Weight (with alkaline batteries) | |
| With standard probe | 230 g |
| With handle | 330 g |
| Materials | |
| Meter body | PC/ABS blend, acrylic display lens |
| Probe holder | PC/ABS blend (grey) |
| Probe | PC/ABS blend (white) |
| Filter | PC (glass reinforced) |
| Housing classification | IP54 |
| Mechanical drop endurance | 0.4 m with probe attached 1.0 m without the probe |

General

| | |
|--|--|
| Power-up time | < 3 s |
| Batteries | 2 × AA sized, 1.5 V |
| Calculated parameters | Td, Tw, a, x, h |
| Menu languages | English, German, French, Finnish, Spanish, Swedish, Chinese (simplified), Russian, Japanese, Portuguese |
| Display | LCD (140 x 160 pixels) |
| Operation time | typical 100 hours (without backlight) |
| Operation temperature range | -10 ... +60 °C (+14 ... +140 °F) |
| Storage temperature range | -30 ... +70 °C (-22 ... +158 °F) |
| Electromagnetic compatibility (EMC) | European Union directive EN61326-1 for portable equipment |

Accessories and Spare Parts

| | |
|---|-------------|
| HMP113 probe for HM40* | |
| HM40 handle and cable | HM40HANDLE |
| Plastic nut for HMP113 attachment (3 pcs) | DRW238590SP |
| NiMH rechargeable batteries (4 pcs) | 229247SP |
| External battery recharger with USB connection and 2 batteries | 229249SP |
| Case for HM40 (indicator and probe) | 235849SP |
| Plastic grid filter for HMP113 probe | DRW236214SP |
| Plastic grid with membrane filter for HMP113 probe | 230727SP |
| Belt clip (3 pcs) | 227710SP |
| Battery cover (3 pcs) | 225688SP |

* See the HM40 order form when ordering a spare probe for HM40.

Dimensions

Dimensions in mm

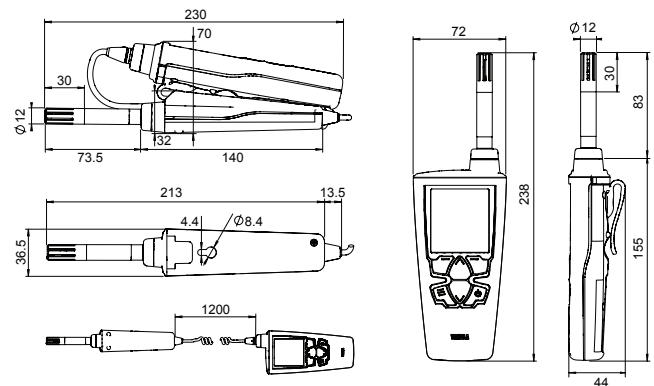

VAISALA

Contact:
Industrial Process Measurement, Inc.
3910 Park Avenue, Unit 7
Edison, NJ 08820
732-632-6400
support@instrumentation2000.com
http://www.instrumentation2000.com

http://www.instrumentation2000.com

Ref. B211064EN-B ©Vaisala 2012
This material is subject to copyright protection, with all copyrights retained by Vaisala and its individual partners. All rights reserved. Any logos and/or product names are trademarks of Vaisala or its individual partners. The reproduction, transfer, distribution or storage of information contained in this brochure in any form without the prior written consent of Vaisala is strictly prohibited. All specifications — technical included — are subject to change without notice.

