

HYGROFLEX5



THE INTELLIGENT TRANSMITTER.

INTRODUCING AIRCHIP DIGITAL TECHNOLOGY.

INNOVATION IN HUMIDITY AND TEMPERATURE MEASUREMENT

- Relative humidity and temperature measurement
- Dew Point and other psychrometric calculations
- Interchangeable probe for easy maintenance
- Wide choice of probes to satisfy every application
- Low voltage and mains versions
- Freely scalable analogue signals
- Various digital outputs available



rotronic
MEASUREMENT SOLUTIONS

SPECIFY THE BEST: HYGROFLEX5 ADVANTAGES AT A GLANCE.

The HygroFlex5-series is the latest development in transmitters for humidity, temperature and dew point. One outstanding feature of this innovative product is the possibility to output any psychrometric calculation as an analogue signal.

The HF5-series is compatible with HygroClip2 probes with integrated AirChip3000 technology – thanks to which the probes achieve an unparalleled degree of accuracy not seen before.

In combination with advances in sensor technology and integration, the HygroFlex HF52, HF53, HF54, HF55 and HF56 transmitters combined with a HC2-S probe provide superb precision and state-of-the-art functionality, taking humidity and temperature measurement to a whole new level of accuracy $< 0.8\% \text{rh}$ and $< 0.1 \text{ K}$ at $23\text{ }^\circ\text{C}$.

Easy to read display

- Display of the measured values on a clear, backlit graphic display with trend indicators
- Configuration by keypad possible

Tried-and-tested housing

- Robust industrial housing
- Wall or duct mount versions

Power supply

- 15...40 VDC/12...28 VAC
- 9...36 VDC/7...24 VAC (galvanically separated)
- 85...240 VAC (galvanically separated)
- Power over Ethernet (PoE)

Output signals

- Two freely selectable and scalable analogue outputs
- Available as 2-wire (HF52), 3/4-wire (HF53) 3/4-wire (HF54, HF56 with galvanic isolation) and digital (HF55) transmitter
- Optional digital outputs allow integration on a network via or RS-485, Ethernet - wired or wireless
- Combined digital and analogue output signals, allow control and monitoring of a device with one transmitter

Wide selection of probes

- Compatible with all HygroClip2 probes
- Use of probe simulators allows easy system validation

AirChip3000

- Compensates humidity and temperature over 30,000 reference points
- Dew/frost point calculation
- Active alarming and information
- ASIC (Application Specific Integrated Circuit), micro-controller and EEPROM on one chip



APPLICATIONS.

The HygroFlex5-series is ideal for all applications where exact measurement of humidity and temperature is of decisive importance, for example the food and pharmaceutical industries, printing and paper industries, meteorology, agricultural sector, archaeology and climatology. There is hardly a field today in which these parameters may be ignored. It is ultimately the measuring task at hand that defines the combination of transmitter and probe that best covers your needs.

HF5 wall version

HF53S /54S/55S series



HF52/53/54/55 series



HF56 series



HF5 duct version



PROBES FOR HYGROFLEX TRANSMITTERS.

Whether you need a simple plug-in probe to measure ambient conditions, or a more sophisticated cable probe for high temperature and other special applications, we can provide you with the ideal HygroClip2 probe to suit your requirements.

All HygroClip2 probes can be individually calibrated and adjusted to increase measurement precision where you need it the most. This capability is exactly what makes every probe in the product range a high-end solution for your application.

Standard Probe

Operating range: - 50...100 °C

Housing: polycarbonate or stainless steel



Industrial Probes for process applications⁽¹⁾

Operating range: -100...200 °C and 0...100 bar (0...1450 PSI)

Variations: polycarbonate or stainless steel

(1): HF520 transmitter is not compatible with industrial metal probes



TECHNICAL INFORMATION.

HF52/53/54/55 Series

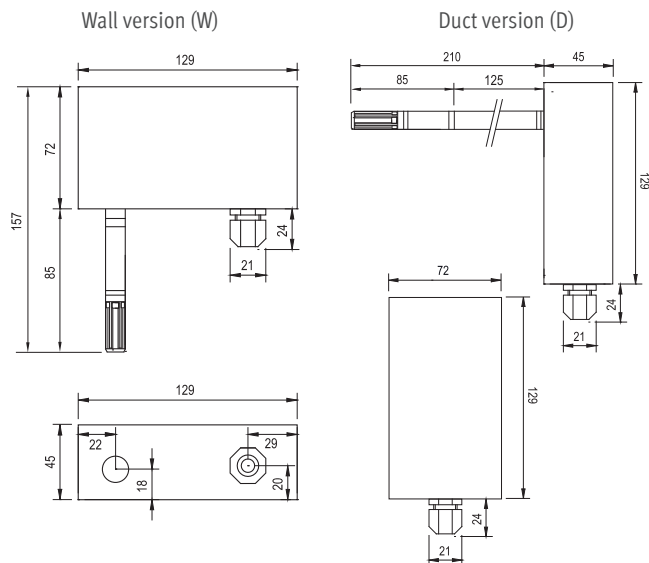

HF56 Series

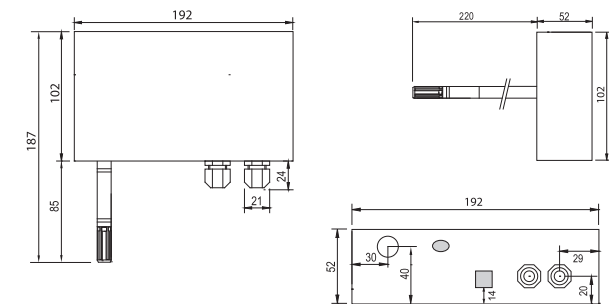

HF53S/54S/55S Series

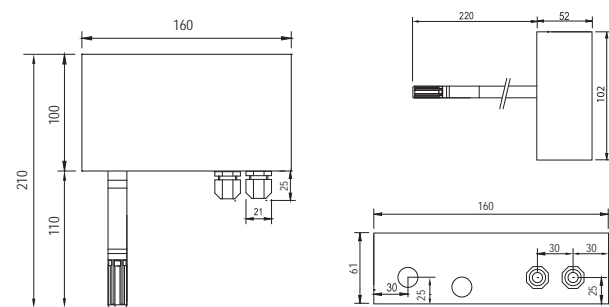

	HF52 2-wire	HF53/54/56 3/4-wire	HF55 Digital
Probe type	HygroClip2 probe, all models ⁽¹⁾		
Probe cable extension	Passive: max. 5 m, active 100 m		
Accuracy at 23 ±5 °C	probe dependent		
Response time τ 63	probe dependent		
Start-up	HF53/54/55/56: typically 3s, HF52: 10s		
Measurement range	probe dependent		
Electronics operating range	HF53/54/55/56: -40...60 °C / 0...100 %rh HF52: -25...60 °C (-10...60 °C with LCD)		
Display (option) (HF52: no backlight)	Graphic display, backlight Parameters configurable		
Trend indicators	Yes		
Output signals (analogue)	Scalable by user 0...1 V, 0...5 V, 0...10 V, 0(4)...20 mA		
Digital outputs (optional)	Ethernet (LAN, WLAN), USB, RS-485		
Power supply	HF52: 10...28 VDC: 10 V+(0.02x load) HF53/55: 15...40 VDC / 12...28 VAC HF54 with galvanic isolation: 9...36 VDC HF56 with galvanic isolation: 85...240 VAC		
Power consumption	HF52: max 40 mA HF53 <100mA, HF55 <300mA		
Circuit type	HF52: 2 x 2 wires, HF53/54/56: 3/4 wires HF55: digital		
Min. / Max. load	V-signal: ≥1 kΩ/V / mA-signal: ≤500 Ω		
Load compensation	Yes		
Firmware update	Via service connector, requires HW4 software		
Sensor diagnostics (drift, state)	Programmable. Default: off		
Humidity adjustment	With keypad/software: multi point (HF53/54/55/56)		
Temperature adjustment	With keypad: 1 point Software: 2 points (HF53/54/55/56)		
Data logging function	External, 2000 data point memory		
Psychrometric calculations	All selectable		
PC interface	With ROTRONIC interface cable HW4 compatible		
Data processing by HW4	Graphs, statistical data and analysis, qualification etc.		
Housing material	ABS / Aluminium (HF5xxS)		
Cable connections	1 x M16x1.5, on terminals		
Standards	CE-compliant, 2007/108/EG		
Audit trail, Electronic Records	FDA 21 CFR Part 11 and GAMP compliant		
IP protection rating & fire	IP65 / Corresponds to UL94-HB protection class		

(1): HF520 transmitter is not compatible with industrial metal probes

Contact:
Industrial Process Measurement, Inc.
3910 Park Avenue, Unit 7
Edison, NJ 08820
732-632-6400
support@instrumentation2000.com
<http://www.instrumentation2000.com>

rotronic
MEASUREMENT SOLUTIONS