

## Temperature Sensors for Liquids and Gases

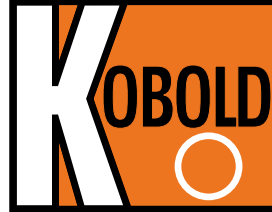

measuring  
•  
monitoring  
•  
analyzing



- Measuring range: -40...150°C
- Measuring accuracy:  
±2.5°C or Pt100  
according to IEC 751
- Connection:  
1/4" ... 1.5" NPT female
- Materials: brass, stainless steel
- PTC or Pt 100 sensor



Contact:  
Industrial Process Measurement, Inc.  
3910 Park Avenue, Unit 7  
Edison, NJ 08820  
732-632-6400  
support@instrumentation2000.com  
<http://www.instrumentation2000.com>

Model:  
TSA

**Description**

The model TSA... temperature sensors respond quickly and operate between -40 and 150°C. A laser-trimmed electronic sensor serves as measuring element in a rugged housing made of brass or stainless steel that is suitable for rough service.

Due to the laser trimming, the output signal of the temperature sensor is strong, therefore no line compensation is required for a supply leads of less than 20 m.

This dependence is linear with a positive temperature coefficient. Control and indicating devices that enable universal service are used to evaluate the output signal.

The temperature sensors are delivered in a housing with female threads from 1/4" to 1.5" NPT and with a 1.5 m silicone-rubber insulated cable.

**Application**

The model TSA sensors are suitable for service in all applications where temperature monitoring, detection or regulation of gases or liquids is required: for example heat exchangers, heating and ventilation systems, air conditioning and cooling plants, and so forth.

**Technical Details**

**Material**

- Housing: brass or 304 stainless steel
- Seal: FKM
- Cable: 1.5 m silicone-rubber-insulated cable
- Max. operating pressure: Brass: 230 PSI  
Stainless steel: 360 PSI
- Media temperature: -40 ... 150 °C
- Max. supply current: 1 mA
- Measuring accuracy: Model TSA-5...: at 20°C: ±0.7°C over the entire measuring range: ± 2.5°C
- Model TSA-6...: category B according to IEC 751 See resistance thermometers for further details

**Resistance values dependent on temperature model TSA-5...**

(with 1 mA max. supply current)		(with 1 mA max. supply current)	
Temperature	Resistance (Ω)	Temperature	Resistance (Ω)
-40 °C	1584 ± 12 (1.9 °C)	+ 60 °C	2314 ± 9 (1.1 °C)
-30 °C	1649 ± 11 (1.7 °C)	+ 70 °C	2397 ± 10 (1.2 °C)
-20 °C	1715 ± 10 (1.5 °C)	+ 80 °C	2482 ± 12 (1.4 °C)
-10 °C	1784 ± 9 (1.3 °C)	+ 90 °C	2569 ± 14 (1.6 °C)
0 °C	1854 ± 8 (1.1 °C)	+100 °C	2658 ± 16 (1.8 °C)
+10 °C	1926 ± 6 (0.8 °C)	+110 °C	2748 ± 18 (2.0 °C)
+20 °C	2000 ± 5 (0.7 °C)	+120 °C	2840 ± 19 (2.0 °C)
+30 °C	2076 ± 5 (0.7 °C)	+130 °C	2934 ± 21 (2.2 °C)
+40 °C	2153 ± 6 (0.8 °C)	+140 °C	3030 ± 23 (2.4 °C)
+50 °C	2233 ± 7 (0.9 °C)	+150 °C	3128 ± 25 (2.5 °C)

**Special Features**

- No line compensation for supply leads < 20 m required
- Linear temperature sensitivity
- Good long-term stability
- Rugged housing for rough service

**Dimensions**

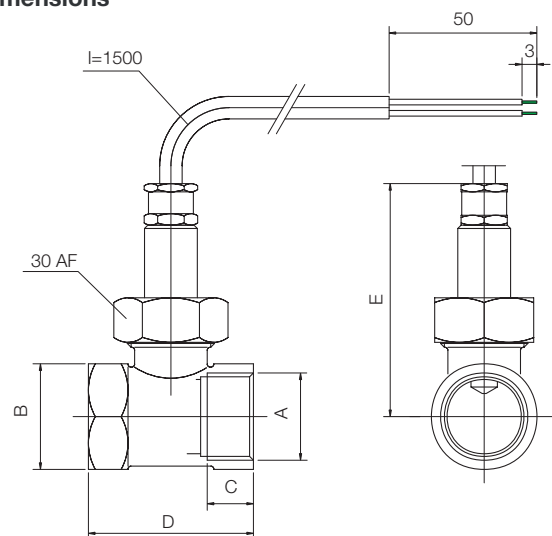

A	B	C	D	E max.
1/4"	27 AF	10	50	77
3/8"	27 AF	10	50	77
1/2"	27 AF	10	50	77
3/4"	32 AF	15	52	78
1"	39 AF	15	56	81

**Evaluating electronics for temperature sensors**

A broad spectrum of transmitters are available for processing the output signal from our temperature sensors. These transmitters convert the signal to a proportional output current (4 - 20 mA), an analog or digital display, or limit relays.

**Order Details** (Example: TSA-6105)

Connection female NPT	Order number (with PTC sensor)		Order number (with Pt100 sensor)	
	Brass	St. steel	Brass	St. steel
1/4"	TSA-5105	TSA-5205	TSA-6105	TSA-6205
3/8"	TSA-5110	TSA-5210	TSA-6110	TSA-6210
1/2"	TSA-5115	TSA-5215	TSA-6115	TSA-6215
3/4"	TSA-5120	TSA-5220	TSA-6120	TSA-6220
1"	TSA-5125	TSA-5225	TSA-6125	TSA-6225
1 1/4"	TSA-5132	TSA-5232	TSA-6132	TSA-6232
1 1/2"	TSA-5140	TSA-5240	TSA-6140	TSA-6240