

PSR/PS PADDLE TYPE FLOW SWITCH



Flow
Pressure
Level
Temperature
measurement
monitoring
control



- Switch Point Adjustable
- Easy to Install
- Brass or SS Construction
- Low Cost
- Maximum Pressure:
1450 PSIG (most models)

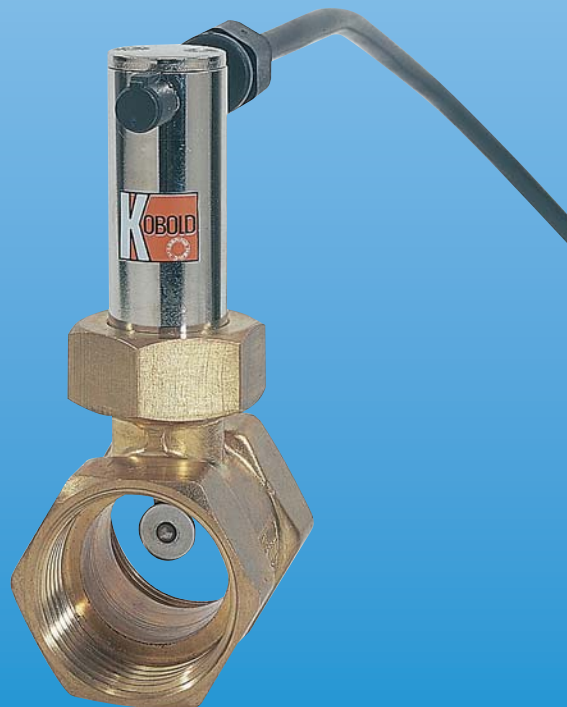

S3

Contact:
Industrial Process Measurement, Inc.
3910 Park Avenue, Unit 7
Edison, NJ 08820
732-632-6400
support@instrumentation2000.com
<http://www.instrumentation2000.com>

Model:
PSR/PS



PSR/PS - Paddle Type Flow Switch

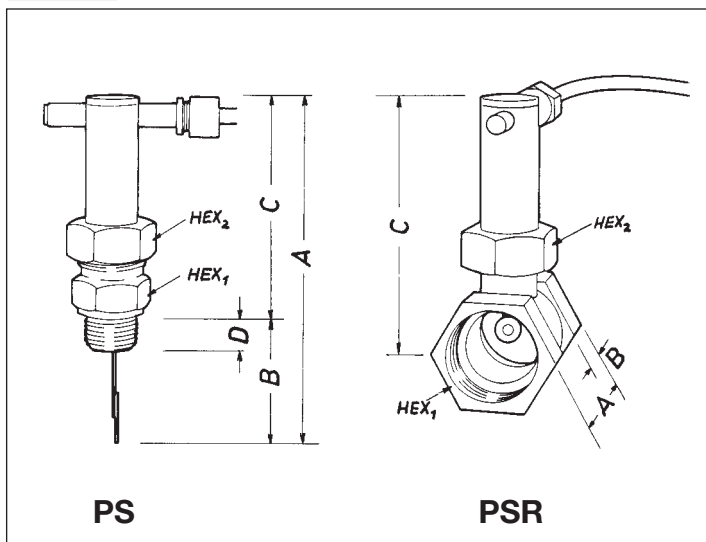

KOBOLD paddle type flow switches can be used wherever a simple economic yet reliable monitoring instrument is required for flow switching applications.

The device operates as follows: The flowing medium presses against the paddle of the KOBOLD flow switch. The paddle is fitted to one end of a balance arm which is in direct contact with a pre-stressed leaf spring. At the other end of the balance arm is a permanent magnet. This magnet actuates a reed contact located within a moveable housing outside the media.

The reed contact switches on or off depending on the position of the permanent magnet and the switch housing. The status of the switch may then be used to electrically control the fluid flow. The movable reed switch on the Kobold PSR/PS allows the contacts to be set either normally open (N/O) or normally closed (N/C).

Specifications

Maximum Temperature: 230°F

Maximum Pressure: 1450 PSIG

(NOTE: 360 PSIG max for PSR-5132 & PSR-5140)

Materials:

Paddle: SS 304

Leaf Spring: SS 301

Beam: SS 301

Locking Plate: brass or SS 304

Contact Housing: Polyamid, glass reinforced, NEMA 4

Cable: PVC

O-Ring: Buna-N for brass units; Viton for SS units

Contact: Reed-switch SPST, N/O or N/C (SPDT Optional)

Maximum Contact Ratings: 50 VA, (50 Watt, 250 VAC, 1.5A)

Standard Cable Length: 5ft

Orientation: Horizontal Pipes

Max Flow: 5x switching range increasing

Order Numbers and Dimensions

Order Number	Dimensions					
	A	B	C	D	HEX ₁	HEX ₂
PS-...49	3.66"	2.32"	1.34"	0.78"	0.87"	-
PS-...52	5.05"	2.22"	3.03"	0.75"	1.06"	1.18"
PS-...14	7.55"	4.52"	3.03"	0.75"	1.06"	1.18"
PSR-...05	1.97"	0.39"	3.15"	-	1.06"	1.18"
PSR-...10	1.97"	0.39"	3.15"	-	1.06"	1.18"
PSR-...15	1.97"	0.39"	3.15"	-	1.06"	1.18"
PSR-...20	2.05"	0.59"	3.21"	-	1.25"	1.18"
PSR-...25	2.20"	0.59"	3.31"	-	1.54"	1.18"
PSR-...32	2.60"	-	3.50"	-	1.97"	1.18"
PSR-...40	2.60"	-	3.62"	-	2.36"	1.18"

U. S. Patent Number 4,827,092

Order Numbers for standard types

Stand. conn. NPT	Switching ranges		Flow switch Model PSR	
	Increasing GPM water	Decreasing GPM water	Brass	SS
1/4"	0.9- 1.3	0.6- 1.2	PSR 5105	PSR 5205
3/8"	1.0- 1.6	0.7- 1.5	PSR 5110	PSR 5210
1/2"	1.3- 2.1	1.0- 2.0	PSR 5115	PSR 5215
3/4"	3.0- 4.0	2.2- 3.0	PSR 5120	PSR 5220
1"	3.2- 5.0	2.4- 4.5	PSR 5125	PSR 5225
1 1/4"	4.9- 8.5	3.8- 7.8	PSR 5132	PSR 5232
1 1/2"	9.2-15.0	7.9-14.3	PSR 5140	PSR 5240

Optional SPDT Reed Switch add Suffix "U"

Order Numbers for standard types

Pipe Size	Switching ranges		Stand. conn. NPT	Flow switch Model PS Material	
	increasing GPM Water	decreasing GPM Water		Brass	SS
2"	18- 24	16- 22	1/2"	PS-5149	PS-5249
3"	48- 66	45- 62	1/2"		
4"	84-106	79-101	1/2"		
6"	185-242	176-237	1/2"	PS-5152	PS-5252
2"	13- 16	11- 15	1/2"		
3"	41- 48	38- 44	1/2"		
4"	57- 70	53- 66	1/2"		
6"	147-159	137-156	1/2"	PS-5114	PS-5214
4"	24- 30	19- 27	1/2"		
6"	53- 75	44- 62	1/2"		
8"	101-141	88-123	1/2"		

Optional SPDT Reed Switch add Suffix "U"

Subject to change without prior notice.