

NWS VIBRATING LEVEL SWITCH



Flow
Pressure
Level
Temperature
measurement
monitoring
control

N1

- **Small and Compact**
- **No Wear Components**
- **Unaffected by External Vibrations**
- **Works with Many Liquids**
- **User Selectable Switch Logic**



Contact:
Industrial Process Measurement, Inc.
3910 Park Avenue, Unit 7
Edison, NJ 08820
732-632-6400
support@instrumentation2000.com
<http://www.instrumentation2000.com>

Model:
NWS

r1_12-13

KOBOLD's NWS level switch works on the vibrating tuning-fork principle. A piezoelectric crystal is matched to the frequency of a tuning fork in air, and used to set the fork vibrating. When the fork becomes immersed in a liquid, its resonant frequency changes. The piezoelectric crystal is then no longer matched to the tuning fork. This causes the vibration to stop. The NWS's internal electronics detects this change and signals an alarm condition.

The NWS is compatible with non-coating and some coating media whose viscosities can range up to 5000 cSt. In addition to the electrical switching control function, an LED signals the status of the switch and the presence of power at the NWS's terminals. The switching logic of the NWS is easily toggled between N/O and N/C by an internal switch.

The NWS is available with a solid state switch which may be used in a 2-wire or 3-wire mode. The 2-wire configuration can switch loads up to 240 VAC at 0.5 amps. The 3-wire system switches a DC voltage when activated.

Technical Data

Media Characteristics

- Type:** liquids or dry granular solids
- Viscosity:** 0.5–5000 cSt (increases response time)
- Max. Pressure:** 650 PSIG @ 270 °F
- Max. Temperature:** 270 °F (medium)
- Response Time:** 1 second
- Repeatability:** ± 1 mm
- Hysteresis:** 4 mm vertical, 1 mm horizontal

Materials of Construction

- Wetted Parts:** 316 SS
- Housing:** Polyamide

Electrical Characteristics

- 2-wire Hook-up Solid State**
 - Supply/Switch:** 24–240 VDC/VAC
 - ON Current:** 500 mA max.
 - OFF Current:** 2–7.5 mA
- 3-wire Hook-up Solid State**
 - Supply:** 24 VDC
 - Signal:** 18 VDC
 - Voltage Drop:** 4.5 V @ 500 mA, 10 V @ 7.5 mA
 - Minimum Current:** 2 mA (switch off)

Protection: NEMA 4X/IP65

Dimensions

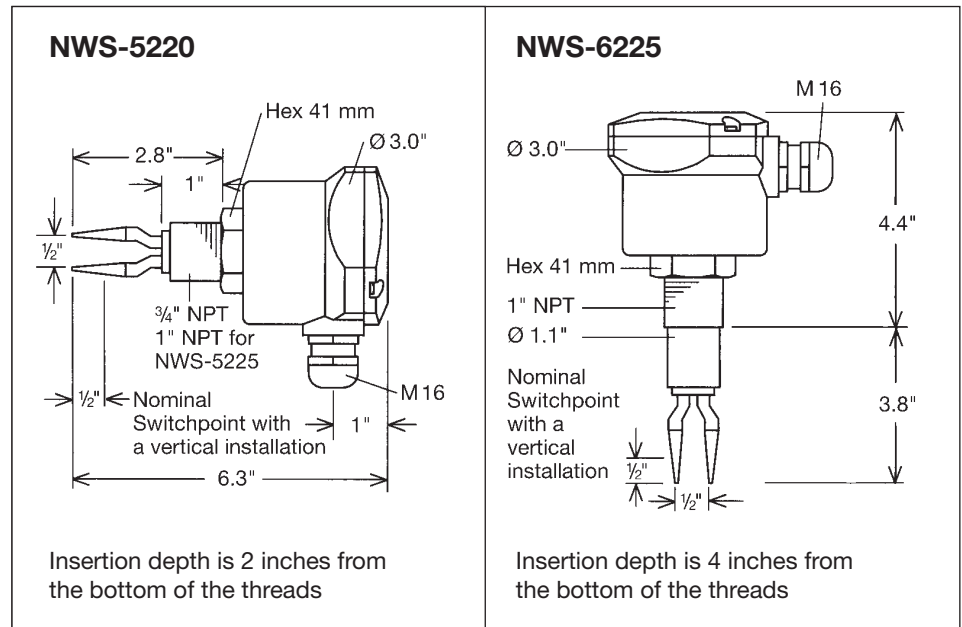

General NWS Usage

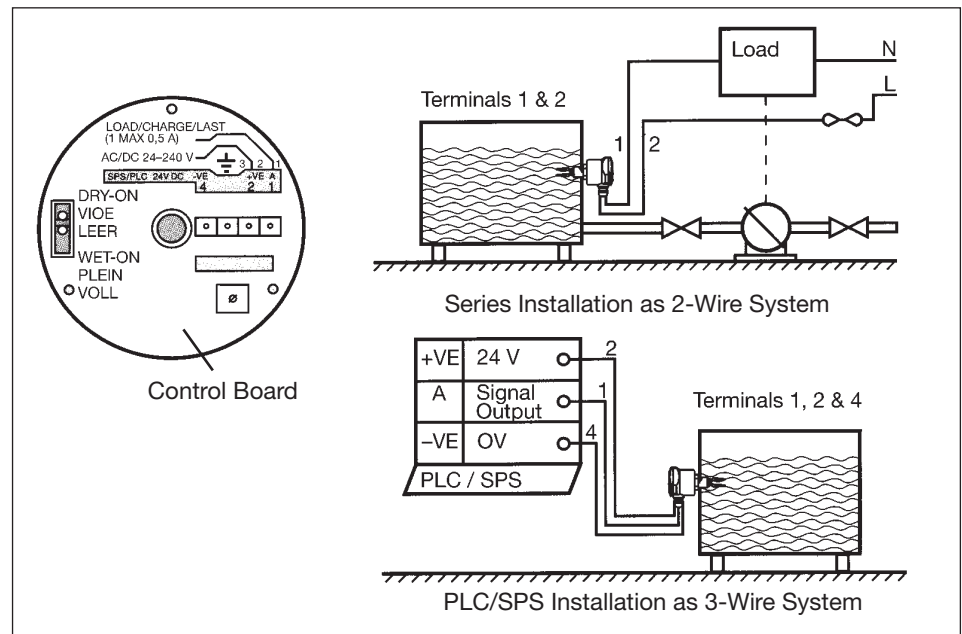

NWS Ordering Information

Insertion Depth	Fittings	Model Number
2"	3/4" NPT	NWS-5220
2"	1" NPT	NWS-5225
4"	1" NPT	NWS-6225
2"	2" Tri-Clamp	NWS-7250
Options		
EP	Custom Insertion Depth up to 40"	