

Magnetostrictive Level Transmitter for Liquids



measuring
•
monitoring
•
analyzing

NMT



- Measuring Length: 300...4000 mm
- Accuracy: ± 1 mm
- Max. Pressure: 145 PSIG
- Media Temperature Range: $-4...158$ °F
- Material: Stainless Steel
- 4-20 mA, 4-Wire Analog Output
- Insensitive to Shock and Vibrations



KOBOLD companies worldwide:

Contact:
Industrial Process Measurement, Inc.
3910 Park Avenue, Unit 7
Edison, NJ 08820
732-632-6400
support@instrumentation2000.com
<http://www.instrumentation2000.com>

KOBOLD Instruments, Inc.



Description

The KOBOLD NMT level transmitter is an accurate, float-controlled sensor designed for continuous level sensing. It is comprised of two parts: the magnetostrictive sensor within the measuring tube and the four-wire transmitter in the connection box. The measurement principle is based on echo time or time of flight. A magnetostrictive wire is tensioned inside the measuring tube and current pulses are transmitted through the wire generating an annular magnetic field around the wire. The wire is axially magnetized by magnets fitted within the float. Due to the positioning of both magnetic fields, a torsional impulse is generated in the vicinity of the float magnet, which propagates with ultrasonic speed in both directions. The distance from the float magnet to the defined zero-point is measured by the echo time principle. The integrated electronic module transforms the signal into a standardized analog signal. Common uses for the NMT include: the chemical industry, pharmaceutical industry, tank farms, power stations, and the process industry.



Specifications

- Accuracy:** ±1 mm
- Measuring Length:** 300...4000 mm
- Length of Measuring Tube:** Measuring Length + 114 mm
- Overall Length:** See Dimensional Drawings
- Standard Float Density:** 1.0 S.G. (1.0 kg/dm³)
- Special Float Density:** 0.7 S.G. (0.7 kg/dm³)
- Operating Temperature:** -4...158 °F
- Max. Operating Pressure:** 145 PSIG

Materials

- Connection:** 316L Stainless Steel
- Measuring Tube:** 316L Stainless Steel
- Float:** UNS 32760 Stainless Steel (1.0 S.G.)
316L Stainless Steel (0.7 S.G.)
- Connection Box:** Aluminum w/ Cable Gland
- Process Connection:** 2" NPT or G2 Male
- Analog Output:** 4-20 mA, 4-wire
- Load:** 500 Ω
- Power Supply:** 24 VDC ± 20%,
Max. 150 mA
- Ingress Protection:** IP 65

Order Details (Example: NMT-1201 N50*)

Description	Model	Connection
Level Transducer with 1.0 S.G. Float	NMT-1201	..N50 = 2" NPT
Level Transducer with 0.7 S.G. Float	NMT-1208	..R50 = G2

*When Ordering: Please specify Measuring Length: "L"
Overall Length of Guide Tube = Measuring Length "L" + 114 mm (Inactive Zones)

Dimensions (mm)

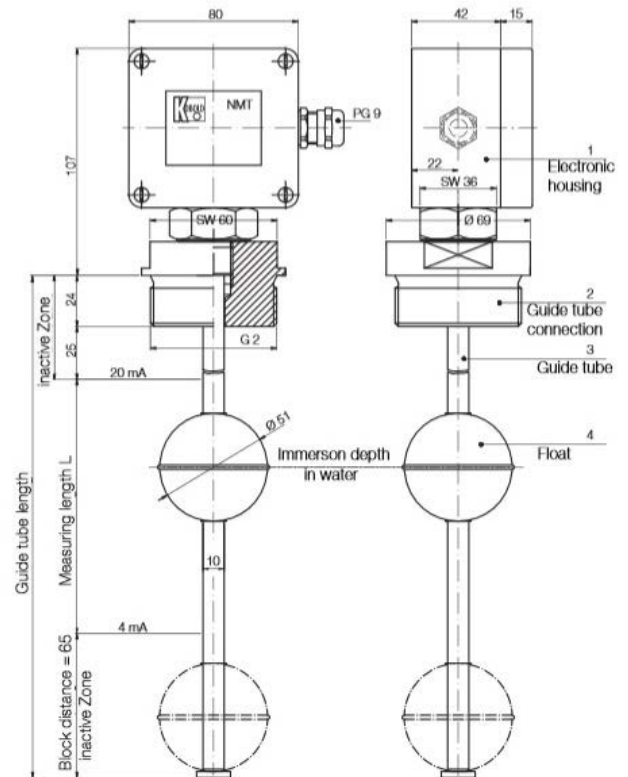

Electrical Connection

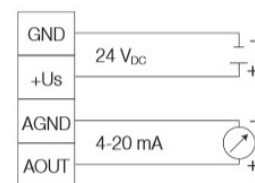

No responsibility taken for errors; subject to change without prior notice.