

MIK
COMPACT MAGNETO-INDUCTIVE FLOWMETER



Flow
Pressure
Level
Temperature
Measurement
Monitoring
Control



- Flow ranges: 0.18...7.8 GPH to 9...180 GPM
- Accuracy: $\pm 2\%$ of full scale
- p_{\max} : 145 psi; t_{\max} : 176 °F
- Connection: G $\frac{1}{2}$...G 2 $\frac{3}{4}$ male native with optional NPT, socket, and hose connections
- Materials: PPS body with stainless steel electrodes; PVDF body with Hastelloy or Tantalum electrodes
- Electronic packages: Frequency or current outputs, adjustable switches, and integral totalizers or batch controllers
- Highlights:
 - no moving parts in the flow body
 - low pressure loss
 - universal mounting
 - high quality at a low price



Contact:
Industrial Process Measurement, Inc.
3910 Park Avenue, Unit 7
Edison, NJ 08820
732-632-6400
support@instrumentation2000.com
<http://www.instrumentation2000.com>

Model:
MIK



Description

The KOBOLD flow meter model MIK is used for measuring and monitoring small to medium-sized flows of conductive liquids in pipes.

The sensor operates according to the electromagnetic measurement principle. According to Faraday's Law of magnetic induction, a voltage is induced in a conductor moving through a magnetic field. The electrically conductive media acts as the conductor. The voltage induced in the media is proportional to the flow velocity and is therefore a value for the volumetric flow. The flowing media must have a minimum conductivity of 30 µS/cm. The induced voltage is picked up by two sensing electrodes which are in contact with the media and sent to the measuring amplifier. The flow rate will be calculated based on the cross sectional area of the pipe.

The measurement is not dependant on the process liquid and its material properties such as density, viscosity, and temperature. The device may be equipped with a switch, frequency, or analog output. Moreover, there is a compact electronic option, which contains a switch and an analog output.

The sensor series is completed by an optional batching or totalizer electronic option. The totalizer electronic option displays the current flow rate on the first line of the display and shows the partial or grand total volume on the second. A batching electronic controls simple filling duties and also measures the flow rate, grand total volume, and filling volume. The analog output and two relay outputs can be utilized for the further processing.

Medias

- Conductivity liquids
- Acids and caustic solutions
- Drinking, cooling, and waste water
- Ground water, raw water
- Aggressive or salty solutions
- Unsuitable for oils & other low or non-conductive medias

Areas of Application

Flow monitoring, flow measuring, batching and totalizing for

- Machine building
- Chemical Industry
- Paper Industry
- Automobile Industry
- Cement Industry
- Laboratories

Technical Data

- Range: see table
- Accuracy: ±2.0% of f. s.
- Repeat accuracy: ±1.0% of f. s.
(f. s. = full scale)
- Measurement process: electromagnetic
- Electrical conductivity: min. 30 µS/cm
- Mounting position: universal,
flow in direction of the arrow
- In-/Outlet: 3 x PD / 2 x PD (pipe diameters)
- Media temperature: -4...+176 °F (max. +140 °F
with PVC-connection set)
- Ambient temperature: +14...+140 °F
- Max. pressure: 145 psi
- Max. pressure loss: max. 3.7 psi at f.s.

Wetted Parts

- Sensor housing: PPS or PVDF, fiberglass-reinforced
- Connection set: NPT, PVC-glue connections, hose barb, or butt weld connections
316L stainless steel
- Electrodes: 316L stainless steel, Hastelloy C4,
or Tantalum
- Seal: NBR, FPM, or FFKM
- Response time t₉₀: ca. 1 s
- Protection: IP 65

Connection/Ranges

Connection	Inside diameter	Flow velocity at f.s.	Range
G ½ male	5 mm	approx. 0.45 m/s	0.18... 7.8 gph
		approx. 0.9 m/s	0.78... 15.6 gph
		approx. 2.7 m/s	2.4... 48.0 gph
G ¼ male	10 mm	approx. 2.2 m/s	0.13 ... 2.6 gpm
		approx. 3.5 m/s	0.2 ... 4.0 gpm
G 1 male	15 mm	approx. 3.0 m/s	0.4 ... 8.0 gpm
		approx. 4.7 m/s	0.65 ... 13 gpm
G 1 ½ male	20 mm	approx. 3.3 m/s	0.8... 16 gpm
		approx. 5.3 m/s	1.3 ... 26 gpm
G 2 male	32 mm	approx. 3.3 m/s	2.0... 40 gpm
		approx. 6.6 m/s	4.0... 80 gpm
G 2 ¾ male	54 mm	approx. 3.6 m/s	6.5... 130 gpm
		approx. 5.1 m/s	9.0 ... 180 gpm

No responsibility taken for errors; subject to change without prior notice.

**MIK-...F300, MIK-...F390**

Pulse output: PNP, Open Collector, max. 200 mA
500 Hz at f. s. (...F300)
50...1000 Hz at f. s. (...F390)
factory set as per customer request

Power supply: 24 V_{DC} ±20%

Power consumption: 60 mA

Electrical connection: plug M 12 x 1

MIK-...S300, MIK-...S30D

Display: duo-LED for switch status

Switching output: relay SPDT, max. 1A/30V_{DC}
or active 24 V_{DC}, N/C / N/O

Switch point: 10 ...100% of f. s. in 10%-Steps
that can be configured by the
customer using a rotary switch

Power supply: 24 V_{DC} ±20%

Power consumption: 80 mA

Electrical connection: plug M 12 x 1, 5-pin

MIK-...L343

Output: 4-20 mA, 3-wire

Max. load: 500 Ω

Spannungsversorgung: 24 V_{DC} ±20%

Power consumption: 80 mA

Electrical connection: plug M 12 x 1

MIK-...L443 (usage with AUF-3000)

Output: 4-20 mA, 3-wire

Max. load: 500 Ω

Power supply: 24 V_{DC} ±20%

Power consumption: 80 mA

Electrical connection: plug DIN 43650

MIK-...C3xx (Compact electronics)

Display: 3-digit LED

Analog output: 4...20 mA adjustable
(only MIK-...C34P)

Max. load: 500 Ω

Switching output: 1(2) semiconductor PNP or NPN,
set at factory

Contact function: N/C / N/O-frequency
programmable

Settings: via 2 buttons

Power supply: 24 V_{DC} ±20%, 3-wire

Power consumption: 120 mA

Electrical connection: plug M 12 x 1

MIK-...Ex4R (Totalizing electronic)

Display: LCD, 2 x 8 digit, illuminated
rate, total, and grand total
unit selectable

Quantity meter: 8-digit

Analog output: 4...20 mA adjustable

Load: max. 500 Ω

Switching output: 2 relays, max. 30V/2 A

Settings: via 4 buttons

Functions: reset, MIN/MAX memory,
flow switch, monitoring for total
and grand total, language

Power supply: 24 V_{DC} ±20%, 3-wire

Power consumption: approx. 150 mA

Electrical connections: cable connection or M 12 plug

MIK-...Gx4R (Batching electronic)

Display: LCD, 2 x 8 digit, illuminated
batching, total, and grand total
unit selectable

Quantity meter: 8-digit

Batch: 5-digit

Analog output: 4...20 mA adjustable

Load: max. 500 Ω

Switching output: 2 relays, max. 30V/2 A

Settings: via 4 buttons

Functions: batching (relay S2), start, stop,
reset, fine batching,
correction amount, flow switch,
total quantity, language

Power supply: 24 V_{DC} ±20%, 3-wire

Power consumption: approx. 150 mA

Electrical connection: cable connection or M 12 plug

Electrical Connections

MIK-...S300

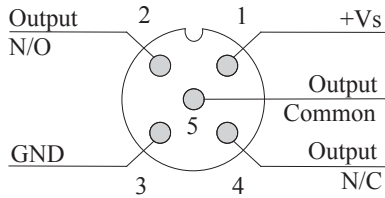

MIK-...S30D

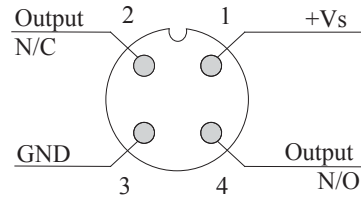

MIK-...L343, MIK-...F3x0

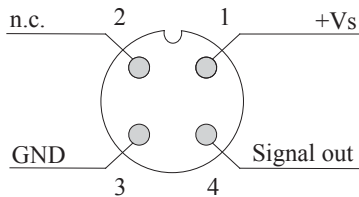

MIK-...L443

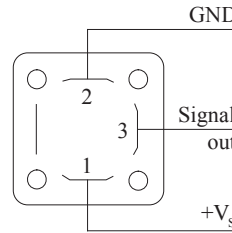

MIK-...C30x

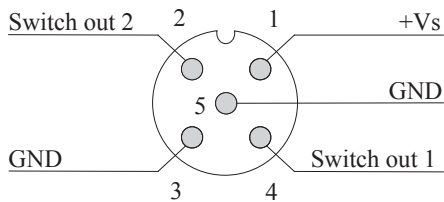

MIK-...C34x

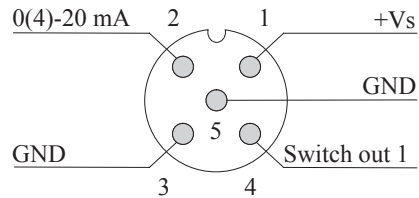

MIK-...E14R, MIK-...G14R Cable Connection

Wire number	MIK-...E14R Totalizing electronics	MIK-...G14R Batching electronics
1	+24 V _{DC}	+24 V _{DC}
2	GND	GND
3	4-20 mA	4-20 mA
4	GND	GND
5	n.c.	Control 1*
6	Reset part quantity	Control 2*
7	Relay S1	Relay S1
8	Relay S1	Relay S1
9	Relay S2	Relay S2
10	Relay S2	Relay S2

Control 1 <-> GND: Start-Batching
 Control 2 <-> GND: Stop-Batching
 Control 1 <-> Control 2: Reset-Batching

Plug Connection

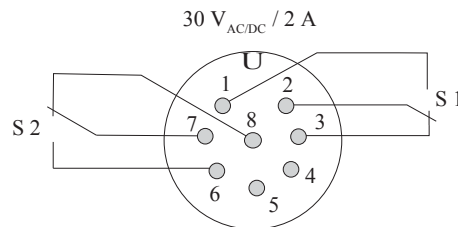
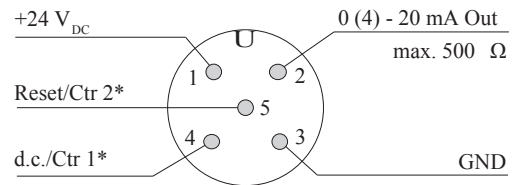



Order Details (Example: MIK-5NA U5 A F300)

Model	Measuring Range, Native Process Connection	Optional Fitting Set	Output/Electronics
MIK-5NA.. = PPS-housing, NBR-seal, stainless steel-electrode	..U0.. = 0.18...7.8 GPH, G ½ ..U1.. = 0.78...15.6 GPH, G ½ ..U2.. = 2.4...48.0 GPH, G ½	..A.. = without ¹⁾ ..N.. = PVC, 1/4" NPT female ..P.. = PVC, 1/2" hose barb	frequency output ..F300 = M12-plug, 500 Hz ..F390 = M12-plug, 50...1000 Hz ²⁾ switching output ..S300 = relay, M12-plug ..S30D = active 24 V _{DC} , M12-plug analog output ..L343 = M12-plug, 4 - 20 mA ..L443 = DIN-plug, 4 - 20 mA compact electronic ..C30R = Open Coll. PNP (2x) ..C30M = Open Coll. NPN (2x) ..C34P = 4 - 20 mA, Open Coll. PNP ..C34N = 4 - 20 mA, Open Coll. NPN totalizing electronic ..E14R = LCD, 4-20 mA, relay (2x), 3' cable ..E34R = LCD, 4-20 mA, relay (2x), M12 plug (2x) batching electronic ..G14R = LCD, 4-20 mA, relay (2x), 3' cable ..G34R = LCD, 4-20 mA, relay (2x), M12 plug (2x)
	..U4.. = 0.13...2.6 GPM, G ¾ ..U5.. = 0.2...4.0 GPM, G ¾	..A.. = without ¹⁾ ..M.. = PVC, 3/8" PVC glue socket ..N.. = PVC, 3/8" NPT female ..P.. = PVC, 3/4" hose barb ..R.. = Polypropylene, 3/8" NPT female	
MIK-5VA.. = PPS-housing, FPM-seal, stainless steel-electrode	..U7.. = 0.4...8.0 GPM, G 1 ..U8.. = 0.65...13 GPM, G 1	..A.. = without ¹⁾ ..H.. = PVDF, 1/2" NPT female ..M.. = PVC, 1/2" glue socket ..N.. = PVC, 1/2" NPT female ..P.. = PVC, 1" hose barb ..R.. = Polypropylene, 1/2" NPT female ..V.. = PVDF, butt weld 20mm O.D. tube ..W.. = 316L SS, 1/2" NPT female ..X.. = Brass, 1/2" NPT female	
MIK-6FC.. = PVDF-housing, FFKM-seal, Hastelloy-electrode	..UA.. = 0.8...16 GPM, G 1½ ..UB.. = 1.3...26 GPM, G 1½	..A.. = without ¹⁾ ..H.. = PVDF, 1" NPT female ..M.. = PVC, 1" glue socket ..N.. = PVC, 1" NPT female ..R.. = Polypropylene, 1" NPT female ..V.. = PVDF, butt weld 32mm O.D. tube	
MIK-6FT.. = PVDF-housing, FFKM-seal, Tantalum-electrode	..UD.. = 2.0...40 GPM, G 2 ..UE.. = 4.0...80 GPM, G 2	..A.. = without ¹⁾ ..H.. = PVDF, 1-1/4" NPT female ..M.. = PVC, 1-1/4" glue socket ..N.. = PVC, 1-1/4" NPT female ..R.. = Polypropylene, 1-1/4" NPT female	
	..UG.. = 6.5...130 GPM, G 2¾ ..UH.. = 9.0...180 GPM, G 2¾	..A.. = without ¹⁾ ..H.. = PVDF, 2" NPT female ..M.. = PVC, 2" glue socket ..N.. = PVC, 2" NPT female ..R.. = Polypropylene, 2" NPT female	
Accessories: P/N 807.037 = 4-pin Micro-DC connector with 6-foot cable for output types F300, F390, L343, & S30D P/N 807.007 = 5-pin Micro-DC connector with 6-foot cable for output types C3xx, S300, E34R, & G34R P/N 807.087 = 8-pin Micro-DC connector with 6-foot cable for output types E34R & G34R			

¹⁾ incl. frontal gaskets (2 pc. O-rings)

²⁾ please specify frequency at full scale in clear text while ordering.

Weight Sensor

Model	PPS	PVDF
MIK-...U0/U1/U2 (½")	approx. 0.40 lb	approx. 0.43 lb
MIK-...U4/U5 (¾")	approx. 0.42 lb	approx. 0.50 lb
MIK-...U7/U8 (1")	approx. 0.60 lb	approx. 0.72 lb
MIK-...UA/UB (1½")	approx. 0.90 lb	approx. 1.10 lb
MIK-...UD/UE (2")	approx. 1.24 lb	approx. 1.35 lb
MIK-...UG/UH (2¾")	approx. 2.65 lb	approx. 3.02 lb

Weight Electronics

Model	Weight
MIK-...F3x0 MIK-...S30x MIK-...Lxx3	approx. 0.18 lb
MIK-...C3xx	approx. 0.67 lb
MIK-...Exxx MIK-...Gxxx	approx. 0.56 lb

Total weight = Weight sensor + Weight electronic

No responsibility taken for errors; subject to change without prior notice.



Dimensions

Model	G	L1	L2	L3	L4	L5	L6	H1	H2
MIK-xxxU0A MIK-xxxU1A MIK-xxxU2A	G ½	118	90	14	46	58	36	43	28
MIK-xxxU4A MIK-xxxU5A	G ¾	122	90	16	46	58	36	43	28
MIK-xxxU7A MIK-xxxU8A	G 1	126	90	18	46	58	36	49,5	29,5
MIK-xxxUAA MIK-xxxUBA	G1 ½	134	90	22	68	80	36	66	31,5
MIK-xxxUDA MIK-xxxUEA	G 2	138	90	24	68	80	36	72	36
MIK-xxxUGA MIK-xxxUHA	G 2 ¾	202	150	26	96	110	75	104	52

MIK-...F3x0, MIK-...S30x, MIK-...L343

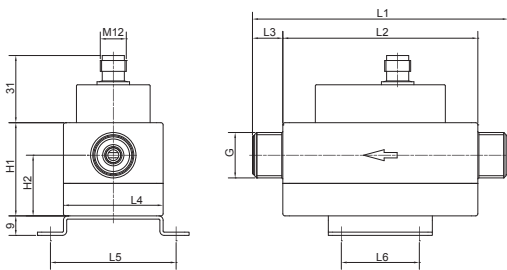

MIK-...L443

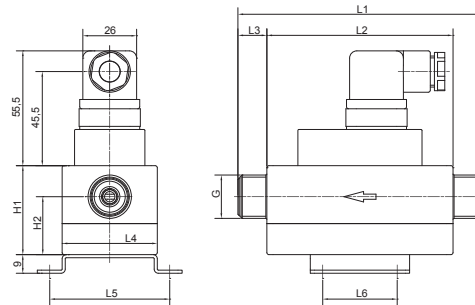

MIK-...C3xx

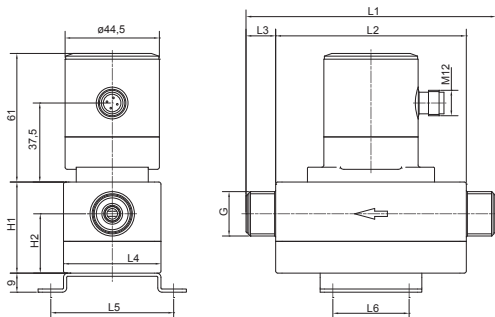

MIK-...Ex4R, MIK-...Gx4R

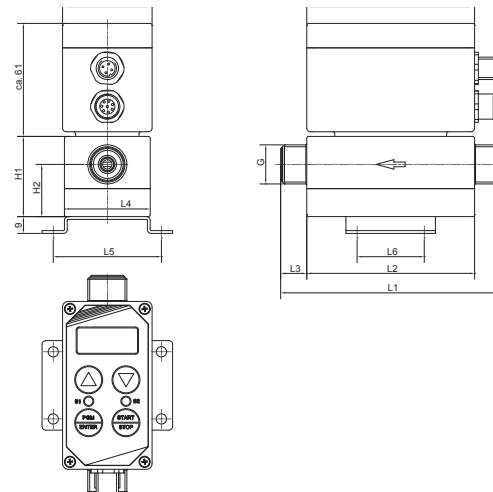

No responsibility taken for errors;
subject to change without prior notice.

Dimensions fitting set ..H, M, N, R, W, X.. connection

Reference table 7.1...table 7.5

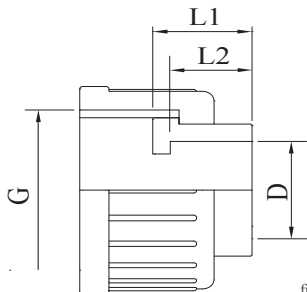

fig. 7.1

Dimensions fitting set ..N.. PVC- 1/4" NPT connection

Reference table 7.1 G ½ only

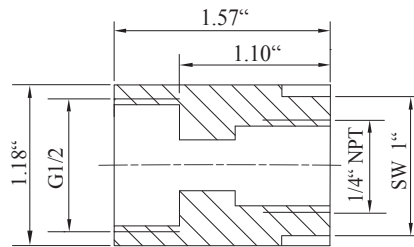

fig. 7.2

Dimensions fitting set ..N.. PVC-NPT connection

G	L1	L2	D
G ½	Refer to figure 7.2		1/4" nom.
G ¾	0.68"	0.52"	3/8" nom.
G 1	0.76"	0.68"	1/2" nom.
G 1 ½	0.98"	0.87"	1" nom.
G 2	1.33"	0.98"	1-1/4" nom.
G 2 ¾	1.61"	0.98"	2" nom.

table 7.1

Dimensions fitting set ..H.. PVDF-NPT connection

G	L1	L2	D
G 1	0.96"	0.79"	1/2" nom.
G 1 ½	1.09"	0.83"	1" nom.
G 2	1.34"	0.91"	1-1/4" nom.
G 2 ¾	1.65"	1.22"	2" nom.

table 7.3

Dimensions fitting set ..M.. PVC-IPS glue connection

G	L1	L2	D
G ¾	0.87"	0.79"	3/8" nom.
G 1	1.0"	0.89"	1/2" nom.
G 1 ½	1.24"	1.14"	1" nom.
G 2	1.51"	1.39"	1-1/4" nom.
G 2 ¾	1.61"	1.5"	2" nom.

table 7.2

Dimensions fitting set ..R.. PP-NPT connection

G	L1	L2	D
G ¾	0.68"	0.55"	3/8" nom.
G 1	0.98"	0.79"	1/2" nom.
G 1 ½	1.24"	0.94"	1" nom.
G 2	1.48"	1.18"	1-1/4" nom.
G 2 ¾	1.68"	1.22"	2" nom.

table 7.4

Dimensions fitting set ..W, X.. SS/Brass-NPT connection

G	L1	L2	D
G 1	1.18"	0.63"	1/2" nom.

table 7.5

Dimensions fitting set ..V.. butt weld

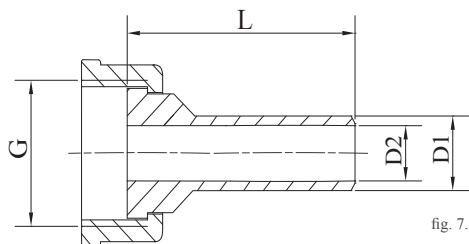

fig. 7.3

G	L	D1	D2
G 1	2.09"	0.79"	0.62"
G 1 ½	2.32"	1.26"	1.05"

table 7.6

Dimensions fitting set ..P.. PVC-hose connection

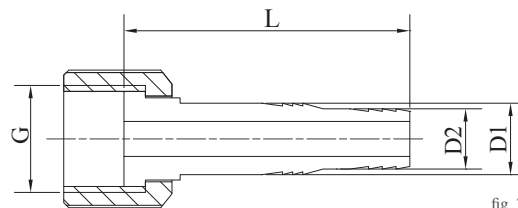

fig. 7.4

G	L	D1	D2
G ½	2.2"	0.55"	0.47"
G ¾	2.36"	0.71"	0.63"
G 1	2.64"	0.87"	0.79"

table 7.7