

## DPM PELTON WHEEL FLOW SENSOR



Flow  
Pressure  
Level  
Temperature  
measurement  
monitoring  
control



- Flow Ranges 0.24-11.1 GPH to 0.8-80 GPH
- Brass or Stainless Steel Bodies
- Pulse or 4-20 mA Outputs
- Long-Life Sapphire Axle/Bearing Assembly
- Compact Design

S4

Contact:  
Industrial Process Measurement, Inc.  
3910 Park Avenue, Unit 7  
Edison, NJ 08820  
732-632-6400  
support@instrumentation2000.com  
<http://www.instrumentation2000.com>

Model:  
DPM



### Features

- Flow ranges 0.24-11.1 GPH to 0.8-80 GPH
- Brass or stainless steel bodies
- Pulse or 4-20 mA outputs
- Long-life sapphire axle/bearing assembly
- Compact Design

The DPM series flow sensor uses the pelton wheel principle to measure the flows of water and low viscosity liquids. Liquid passes through a nozzle at the inlet of the flow body and is precisely directed onto a flat blade pelton turbine. The turbine wheel rotates at a speed which is proportional to flow rate. The movement of the pelton wheel is detected optically. The signal from the optical sensor is processed as an amplified pulse or 4-20 mA signal which are proportional to flow rate. In addition to the compact design, the inlet flow is redirected via a nozzle, therefore no inlet or outlet straight piping is required and the sensor can be mounted in any orientation. These features make the DPM ideal for mounting in locations where space is tight.

### Specifications

**Accuracy:** ±1.5% of full scale

**Maximum Pressure:** 230 PSIG

**Operating Temperature:** -10 to 176°F

#### Materials of Construction

**Housing:** 316L stainless steel or brass depending on model number

**Nozzle:** 316L stainless steel  
**Axle/Bearing:** Sapphire

**Pelton Wheel:** Polypropylene

**Receiver:** Polysulfone

**O-ring:** Buna-N for brass housings, Viton for 316L SS housings



**KOBOLD DPM Series Pelton Wheel Turbine**

### Electrical Specifications

#### Frequency Output

**Output Type:** PNP open collector, 25 mA max.

**Input Power:** 24 VDC ±20%

**Frequency Range:** Based on model number

**Electrical Protection:** NEMA 4X/IP 65

**Electrical Connection:** 6 ft. PVC cable or Micro-DC plug, 4-pin male

#### 4-20 mA Output

**Output Type:** 4-20 mA, 3-wire

**Max. Loop Load:** 500 ohms

**Power Requirement:** ±24 VDC 20%

**Electrical Protection:** NEMA 4X

**Electrical Connection:** Micro-DC plug, 4-pin male or DIN 43650 (hirschmann) plug

#### Compact Electronics

**Output Types:** Analog output with 1 open collector switch or 2 open collector switches

**Analog Output:** 4-20 mA, 3-wire RL<500 ohms

**Switch Type:** PNP open collector based on ordering code

**Switch Rating:** 300 mA Max. short circuit protected

**Power Requirement:** 24 VDC ±20%

**Display Type:** 3 digit LED

**User Programmable Functions:** Transmitter span, switch setpoint, lockout code

**Housing:** 304 SS, NEMA 4X

**Electrical Connection:** Micro-DC plug, 5-pin male

Ordering Information

Range GPH Water	DP at Max. Flow (PSI)	Housing Material		Fitting Size	Output/Electronic
		Brass	316L SS		
0.24-11.1	16.8	DPM-1157...	DPM-1557...	N1=1/8" NPT N2=1/4" NPT	<b>F300</b> = Frequency output Micro-DC plug  <b>F500</b> = OEM Frequency output with 6ft. PVC cable  <b>L343</b> = 4-20 mA, 3-wire output with Micro-DC Plug  <b>L443</b> = 4-20 mA, 3-wire output with DIN 43650 plug  <b>C34P</b> = Compact electronics 4-20 mA + 1 PNP switch  <b>C30R</b> = Compact electronics 2 PNP switches  <b>Z340</b> = Analog Indicator +4-20 mA, 3-wire
0.8-15.0	17.7	DPM-1160...	DPM-1560...		
0.8-30.0	13.2	DPM-1170...	DPM-1570...		
0.8-48.0	8.8	DPM-1180...	DPM-1580...		
0.8-60.0	8.3	DPM-1190...	DPM-1590...		
0.8-80.0	8.3	DPM-1195...	DPM-1595...		
<b>Accessories</b>					
Part Number 807.037= Mating 4 pin Micro-DC connector with 6 ft. cable for output F300 & L343					
Part Number 807.007= Mating 5 pin Micro-DC connector with 6 ft. cable for output C34P & C30R					

Example: DPM-1157N1F300

DIMENSIONS

Compact Electronics

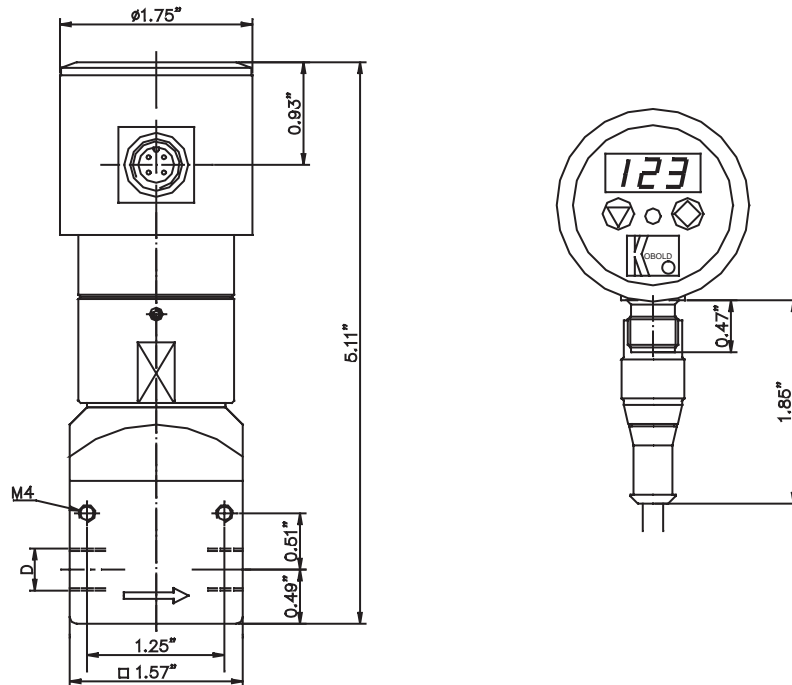

S4

DIMENSIONS

OEM Frequency Output

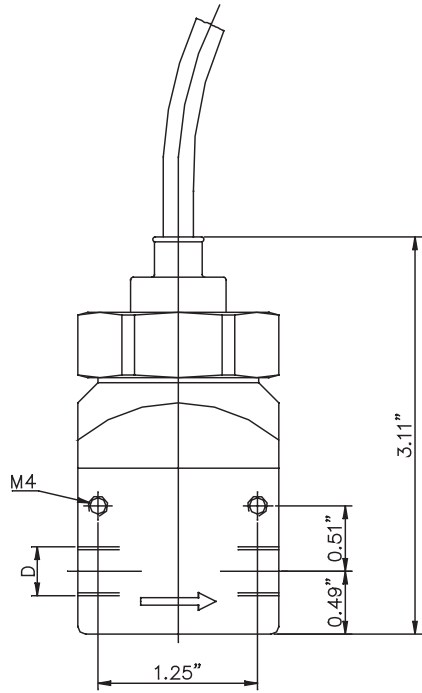

DPM w/ Micro-DC Plug

