

Features

- SS Design for High Corrosion Resistance
- Suitable for Highly Viscous Media
- Tolerates Crystal Formation
- Durable Diaphragm Element
- Optional Glycerin Filled Indicator

KOBOLD's DPF76 pressure gauges feature stainless steel construction for superb chemical and corrosion resistance for all your intermediate pressure applications.

Glycerin filling is available.

Specifications

Ranges: -14.7 to 300 PSIG
(see table)

Over Pressure Protection
Momentary: x 1.3 range max.

Sensing Element: diaphragm

Accuracy: $\pm 1.6\%$ of full scale

Operating Temperature
Medium: freezing to 180°F
Ambient: freezing to 140°F

Fittings: 1/2" NPT

Materials of Construction

Wetted Parts:

Element: SS (Duatherm 600)

Fitting: 316 Ti & 304 SS

Exterior

Movement: Stainless steel

Housing: 304 SS or aluminum

Bezel: 304 SS

Pointer: Black aluminum

Indicator Dial: White aluminum

Gauge Window: Safety glass

Options: Glycerin damped indicator assembly



P1

KOBOLD DPF76 Pressure Gauge

DPF76 Ordering Information			
DPF76	= Diaphragm Pressure Gauge for Intermediate Pressures		
-1	= 100 mm (4 inch) Dial Face, with Stainless Steel Housing		
-2	= 160 mm (6 inch) Dial Face, with Aluminum Housing		
Range	= Pressure Range Abbreviation	Available Measuring Ranges	
H00	= -30" to 0" Hg	130 = 30 PSIG	210 = 100 PSIG
115	= 15 PSIG	160 = 60 PSIG	220 = 200 PSIG
216	= 160 PSIG	230 = 300 PSIG	
F	= Glycerin damped indicator assembly	Options	
Sample DPF76 Specification			
DPF76	-2	130	F

Dimensions

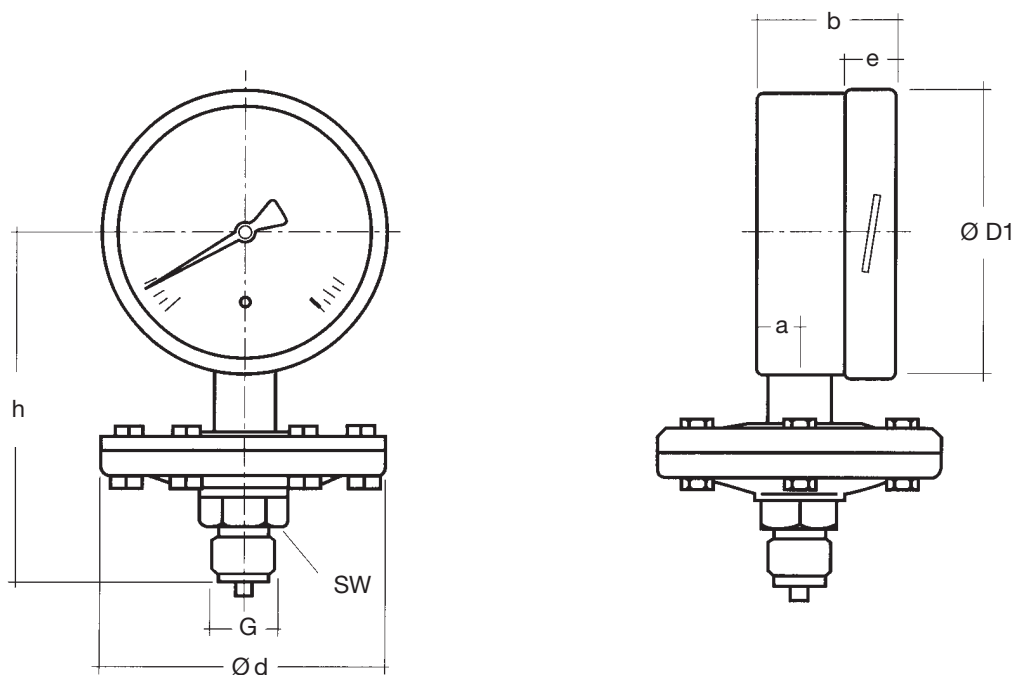

Dial Face	Dimensions (mm)								Weight (lbs)
	Ø d	a	b	Ø D1	e	G	h±2	SW	
4 inch	100	15.5	50	100	17.5	1/2" NPT	125	(27) 22	2.1
6 inch	100	15.5	50	160	17.5	1/2" NPT	175	(27) 22	3.0