



**KANOMAX**  
*The Ultimate Measurements*

**2013**

Spring

**General Catalog**

# Ultimate Measurement Instruments



HVAC Testing

Indoor Air Quality

Industrial Hygiene



Cleanroom Contamination Control

Industrial Flow Testing



Aerosol Research

Fluid Mechanics Research



Anemometers / Indoor Air Quality Monitors / Gas Monitors / Dust Monitors / Sound Meters / Vibration Meters / Particle Counters  
Cleanroom Monitoring System / Aerosol Research Instruments / Mass Spectrometer / Automotive Testing Instruments / Fluid Mechanics Research

# Kanomax Group

Since our inception 60 years ago, Kanomax has been the most promising manufacturer of a broad range of precision measuring instruments for fluid mechanics research, environmental, aerosol research, particles measurement, and customized system applications. As a company that prides itself in technology, product quality, and service, we have been enjoying an unsurpassed reputation in the industrial and academic fields.

## Global Network

Our direct subsidiaries and Kanomax's affiliates and well-trained distributors worldwide are there to provide the most efficient support and service for you. Our global network is always listening to the voice of customers, like you, in order to keep providing the best measurement solutions possible.

- Kanomax Holdings Inc. (New York, NY)
  - Kanomax USA Inc. (Andover, NJ)
  - Shenyang Kano Scientific Instrument Co., Ltd (China)
- Kanomax Corporation (Osaka, Japan)
  - Kanomax Japan Inc. (Osaka-Tokyo-Nagoya, Japan)
  - Kanomax Instrument Shenyang Inc. (China)

## ISO Certification

Kanomax is an ISO 9001/ISO14001 certified company. Kanomax management and production procedures adhere to these international quality standards.



# Kanomax Provides Outstanding Solutions

### Environmental Measurements

- HVAC Testing
- Indoor Air Quality
- Industrial Testing



### Aerosol/Particle Measurements

- Cleanroom Contamination Control
- Aerosol Research



### Fluid Measurements

- Fluid Mechanics

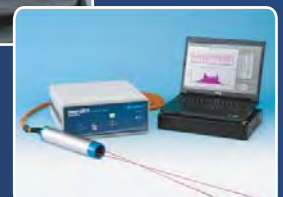

# Calibration facility ensures accuracy and repeatability

Kanomax fully understands service is an essential part of the total solution provided to our valued customers. Having already established a worldwide service network, we continuously strive to improve our support services.

For reliable measurements it is recommended that all instruments be calibrated on an annual basis. This ensures ongoing credibility and accuracy. Our calibration laboratory in New Jersey maintains the most accurate wind tunnel of its kind. Kanomax provides the highest quality of service available with a quick turnaround time. Our service specialists are well trained and will calibrate your instruments to the highest standards.

Our lab certifies Kanomax product to NIST standards.



High Velocity Wind Tunnel



Open Jet Wind Tunnel



Particle Generator

## Featured Products



Handheld Anemometers

Capture Hood



50LPM Flow Rate  
Portable Particle Counter



Mass Spectrometer



Formaldehyde Monitor

Applications

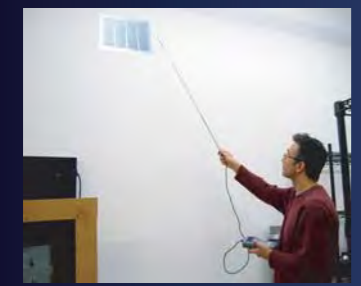

HVAC testing and balancing

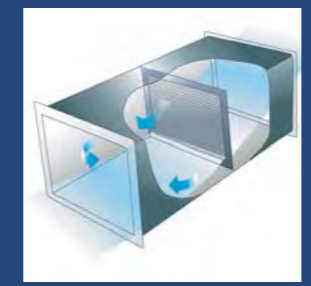

Testing airflow rate of ventilation

# Handheld Anemometers



### Anemomaster™ Lite

Palm-size and feather-weight standard hot-wire Anemometer

- Compact and lightweight
- Easy replacement of probe without recalibration
- Data Hold function
- Includes probe with 59 in (150cm) cable, and 4 pcs. AA batteries

### Anemomaster™ Professional & Standard

Telescopic, articulating probe is designed for HVAC testing and balancing applications

- Simultaneous display of temperature and airflow or air velocity
- Telescopic, articulating probe
- Data HOLD function, Record and recall MAX / MIN / AVG
- Store up to 1,500 measurements
- Data processing software allows real-time measuring and downloading data to PC
- Complete with telescopic probe with 79 in (200cm) cable, Data processing software, USB cable, AC adapter, 6 pcs. AA batteries, carrying case, and NIST Certificate

### Climomaster™ Series

Multi-function hot-wire Anemometer with detachable compatible probes

- Simultaneously measures and displays air velocity, flow rate, humidity, temperature, and differential pressure
- 8 interchangeable probes are available for various applications
- Smart probe technology: easy probe replacement without recalibration of the main unit
- Data HOLD function, Record and recall MAX / MIN / AVG
- Store up to 20,000 measurements
- Data processing software allows real-time measuring and downloading data to PC
- Includes probe, 79 in (200cm) probe cable, 6 pcs. AA batteries, carrying case, and NIST Certificate

### Anemomaster™ Model 6810 Series

Rotating Vane Anemometer with High Accuracy from 40 to 7800 fpm

- 2 sizes of vane heads are available for user's applications
- Industrial grade enclosure and metal vane probe
- Data HOLD, Record and recall MAX / MIN
- Complete with metal vane sensor (choice of 2.75" or 1.00" diameter) with 5 ft long cable, extension rod with handle grip, flexible extension rod, 3 pcs. AA batteries, carrying case, and NIST Certificate

### Specifications

Model	6006	6036/6035	6501	6812/6813/6815
Sensor Type	Hot-wire	Hot-wire	Hot-wire	Rotating Vane
Air Velocity Ranges				
ft/min	2 to 3940	2 to 6000	2 to 9840	40 to 7800
m/s	0.01 to 20.0	0.01 to 30.0	0.01 to 50.0	0.2 to 40
Resolution	0.01 m/s	0.01 m/s	0.01 m/s	0.01 m/s
Accuracy	+/- 5% of reading or 0.015 m/s whichever is greater	+/- 3% of reading or 0.015 m/s whichever is greater	+/- 2% of reading or 0.015 m/s whichever is greater	+/- 1% of reading
Air Flow CFM (ft <sup>3</sup> /min)	n/a	0 to 2,709,360	0 to 2,709,360	0 to 9,999
Temperature Ranges	-4 to 158°F (-20 to 70°C)	-4 to 158°F (-20 to 70°C)	-4 to 158°F (0 to 70°C)	-22 to 212°F (30 to 100°C)
Accuracy	+/- 1°F (0.5°C)	+/- 1°F (0.5°C)	+/- 1°F (0.5°C)	+/- 0.5°F (0.3°C)
Relative Humidity Ranges	n/a	n/a	0.2 to 98.0 %RH	5.0 to 95.0 %RH
Accuracy	n/a	n/a	+/- 2% of reading	+/- 2% of reading
Differential Pressure Ranges	n/a	+/- 5.00 kPa *Option	+/- 5.00 kPa *Option	n/a
Accuracy	n/a	+/- (3% of reading +0.01) kPa	+/- (3% of reading +0.01) kPa	n/a
Dimensions				
Main Unit	W2.4" x H4.7" x D1.2"	W3.4" x H7.4" x D1.6"	W3.4" x H7.4" x D1.6"	W3.3" x H6.3" x D1.5"
Probe	0.24" (6.1 mm) in diameter	0.24" (6.1 mm) in diameter	1.0 to 10 mm in diameter	Vane: 2.75" or 1.00" in diameter
Weight	0.4 lbs (180 g)	0.9 lbs (400 g)	0.9 lbs (400 g)	0.95 lbs (430 g)

# Climomaster™ Model 6501 Series

Multi-function hot-wire anemometer with detachable compatible probes

## Features:

- Simultaneously measures and displays air velocity, flow rate, humidity, temperature, and differential pressure
- Airflow rate calculation based on registered duct size
- Data HOLD function, Record and recall MAX / MIN / AVG
- Store up to 20,000 measurements
- 8 interchangeable probes are available for various applications
- Smart probe technology: easy probe replacement without recalibration of the main unit
- Includes 79 in (200cm) probe connection cable, USB cable, 6 pcs. AA batteries, carrying case, and NIST Certificate

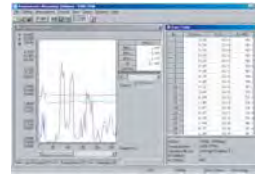

Optional data processing software allows real-time measuring and downloading of data to your PC



As well as HVAC testing, Climomaster and its probes are suitable for IAQ investigation, laboratory control, cleanroom control, and industrial applications, such as automotive.

## Main Unit Specifications

<b>Air Velocity Ranges</b>	2 to 9840 fpm (0.01 to 50.0 m/s) *Varies by probe
<b>Accuracy</b>	+/- 2% of reading or 0.015 m/s whichever is greater
<b>Temperature Ranges</b>	-4 to 158°F (-20 to 70°C)
<b>Accuracy</b>	+/- 1.0°F (0.5°C)
<b>Relative Humidity Ranges</b>	2.0 to 98.0%RH *Varies by probe
<b>Accuracy</b>	+/- 2.0%RH
<b>Differential Pressure Ranges (Option)</b>	+/- 5.00 kPa
<b>Accuracy</b>	+/- (3% of reading + 0.01) kPa
<b>Interface</b>	USB / RS232C (for print-out)
<b>Datalogging</b>	Up to 20,000 records
<b>Analog Output (Option)</b>	0 to 1 V
<b>Power Supply</b>	6 x AA Batteries or AC Adapter
<b>Dimensions</b>	W3.4" x H7.4" x D1.6" (88 x 188 x 41 mm)
<b>Weight</b>	0.9 lbs (400 g)

## Probe Specifications

								
<b>Model</b>	6531-2G	6541-2G	6561-2G	6542-2G	6533-2G	6543-2G	6551-2G	6552-2G
<b>Probe Type</b>	Uni-Directional	Uni-Directional	Uni-Directional	Omni-Directional	Omni-Directional	Omni-Directional	Mini-Spherical	Mini-Spherical
<b>Air Velocity</b>	2 to 6000 fpm	2 to 6000 fpm	2 to 9840 fpm	2 to 6000 fpm	2 to 1000 fpm	2 to 1000 fpm	2 to 6000 fpm	2 to 6000 fpm
<b>Temperature</b>	-4 to 158°F	-4 to 158°F	-4 to 158°F	-4 to 158°F	-4 to 158°F	-4 to 158°F	n/a	n/a
<b>Relative Humidity</b>	2.0 to 98.0 %RH	n/a	n/a	n/a	2.0 to 98.0 %RH	n/a	n/a	n/a

## Accessories

- 6501-AE Main Unit with Analog Output
- 6501-BE Main Unit with Pressure Sensor
- 6531-04: Telescopic Extension Rod (Flex-Neck, extends to 38")
- 6531-05: Telescopic Extension Rod (Straight, extends to 34")
- 6531-06: 2m Probe Cable (also available in 5, 10, 20m)
- 6000-41: Data Processing Software (for Windows)
- 6000-31: Printer Cable for DPU-S245
- 6000-61: Hands Free Case
- 6113-02: AC Adapter
- DPU-S245: Portable Thermal Printer
- TP-202L: Rolled Printer Paper (10 rolls)



6531-04



6000-61



# Anemomaster™ Professional & Standard

Multi-function hot-wire Anemometer with Telescopic, articulating probe

## Features:

- Simultaneous display of temperature and airflow or air velocity
- Telescopic probe measures air velocity and temperature in air ducts, vents, and small openings
- Data HOLD function, Record and recall MAX / MIN / AVG
- Store up to 1,500 measurements (Professional only)
- Data processing software allows real-time measuring and downloading data to your PC (Professional only)
- Includes telescopic probe with 79 in (200cm) cable, Data processing software (Professional only), USB cable (Professional only), AC adapter, 6 pcs. AA batteries, carrying case, and NIST Certificate



Telescopic probe is designed for HVAC testing and balancing applications

## Applications:

- HVAC Testing
- Facility Maintenance
- Critical Environment Certification
- IAQ Investigations

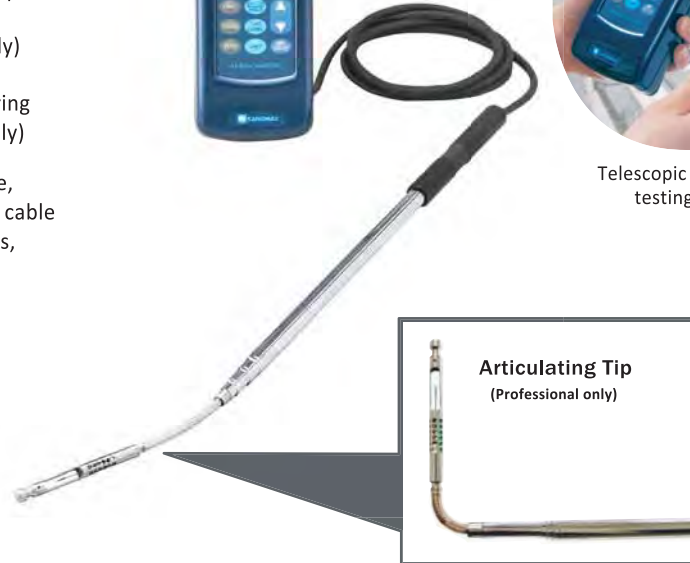

Articulating Tip (Professional only)

## Specifications

Model	Anemomaster™ Professional Model 6036	Anemomaster™ Standard Model 6035
Probe Type	Telescopic and Articulating tip	Telescopic
Air Velocity Ranges	2 to 6000 fpm (0.01 to 30.0 m/s)	
Accuracy	+/- 3% of reading or 0.015 m/s whichever is greater	
Temperature Ranges	-4 to 158°F (-20 to 70°C)	
Accuracy	+/- 1.0°F (0.5°C)	
Differential Pressure Ranges	+/- 5.00 kPa *Option	
Accuracy	+/- (3% of reading + 0.01) kPa	
Interface	Digital USB / (RS232C for print-out)	(RS232C for print-out)
Analog (Option)	DC 0 to 3 V (only for air velocity measurements)	
Datalogging	Up to 1500 records	None
Power Supply	6 x AA Batteries or AC Adapter	
Dimensions	W3.4" x H7.4" x D1.6"	
Weight	0.9 lbs (400 g)	

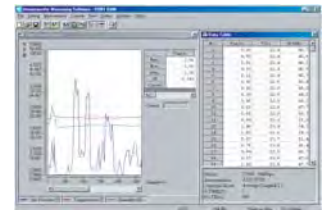

Windows 7 compatible software included

## Accessories

- 6036-AE: Professional with Analog Output
- 6036-BE: Professional with Pressure Sensor
- 6035-AE: Standard with Analog Output
- 6035-BE: Standard with Pressure Sensor
- 6000-31: Printer Cable for DPU-S245
- 6000-61: Hands Free Case
- DPU-S245: Portable Thermal Printer
- TP-202L: Rolled Printer Paper (10 rolls)

## Theory of thermal (hot-wire) type Anemomaster™

The air velocity sensor is heated and temperature elevated (relative to the surrounding air) by means of control electronics. The temperature compensation sensor senses the ambient, or surrounding air temperature, and forces the velocity sensor to stay at a constant overheat above the ambient. The circuit forces the voltage to be equal by means of an operational amplifier. Air flowing past the sensor tends to cool the sensor, thus driving down its resistance. The amplifier responds by immediately delivering more power to the circuit to maintain voltage equilibrium. Delivered power is converted into electrical signals to display.

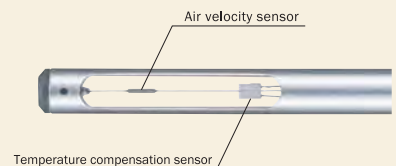



# Anemomaster™ LITE

Palm-size and feather-weight standard hot-wire Anemometer

### Features:

- Compact and lightweight
- Display switchable in m/s or ft/min (FPM) for air velocity and °F and °C for air temperature
- Easy replacement of probe without recalibration
- Average measurements over 1 or 5 seconds for air velocity
- Data Hold function
- 4 pcs. AA batteries, extension rod, carrying case and NIST certificate



Specifications	
Model	6006
Air Velocity Ranges	2 to 3940 fpm (0.01 to 20.0 m/s)
Accuracy	+/- 5% of reading or 0.015 m/s whichever is greater
Temperature Ranges	-4 to 158°F (-20 to 70°C)
Accuracy	+/- 1.0°F (0.5°C)
Power Supply	4 x AA Batteries
Dimensions	W2.4" x H4.7" x D1.2"
Weight	0.4 lbs (180 g)

### Accessories

- 6006-2G: Replacement Probe
- 6112-03: Spare Extension Rod
- 6006-02: Spare Hard Carrying Case

# Anemomaster™ Model 6113/6114

High velocity (up to 50m/s), multi-function hot-wire Anemometer

### Features:

- Simultaneous measurements of air velocity, air temperature, and differential pressure
- Large, easy to read LCD display
- Durable body
- Model 6113 includes built-in printer
- Complete with probe with 79 in (200cm) cable, extension rod, shoulder strap, 6 pcs C cell batteries and NIST Certificate



Specifications	
Model	6113 : 6114
Air Velocity Ranges	20 to 9840 fpm (0.10 to 50.0 m/s)
Accuracy	+/- (3% of reading + 0.1 m/s)
Temperature Ranges	32 to 212°F (0 to 100°C)
Accuracy	+/- 2.0°F (1.0°C)
Differential Pressure Ranges	+/- 5.00 kPa *Option
Accuracy	+/- (3% of reading + 0.01 kPa)
Interface	RS232C
Datalogging	100 measurements
Analog Output	0 to 1 V *Option
Built-in Printer	○ : —
Power Supply	6 x C cell Batteries
Dimensions	W7.9" x H5.9" x D3.9"
Weight	2.2 lbs (1 kg)



### Accessories

- 6113-01: Spare Probe
- 6113-02: AC Adapter
- 6113-03: Extension Rod
- 6113-04: Shoulder Strap
- 6113-07: Pressure Sensor
- 6113-08: Analog Output
- 5600-00: Data Processing Software
- 6000-02: Communication Cable to PC
- TP-202L: Rolled Printer Paper (10 rolls)



# Anemomaster™ Model 6810 Series

## Rotating Vane Digital Anemometer

### Features:

- High Accuracy from 40 to 7800 feet per minute
- 2 sizes of vane heads are available for user's applications
- Industrial grade enclosure and metal vane probe
- Large display with backlight
- Data HOLD, Record and recall MAX / MIN
- Includes metal vane sensor (choice of 2.75" or 1.00" diameter) with 5 ft long cable, extension rod with handle grip, flexible extension rod, 3 pcs. AA batteries, carrying case, and NIST-Traceable calibration certificate



1 inch Air Velocity Probe

Anemometers / Air Velocity Meters

Specifications	6812		6813		6815 comes with HTP202	
<b>Model</b>	6812		6813		6815	
<b>Air Velocity Ranges</b>	2.75" Head	1.00" Head	2.75" Head	1.00" Head	2.75" Head	1.00" Head
ft/min	40 to 7800	300 to 6890	40 to 7800	300 to 6890	40 to 7800	300 to 6890
m/s	0.20 to 40.0	1.5 to 35.0	0.20 to 40.0	1.5 to 35.0	0.20 to 40.0	1.5 to 35.0
<b>Resolution</b>	1 FPM or 0.01 m/s		1 FPM or 0.01 m/s		1 FPM or 0.01 m/s	
<b>Air Flow CFM (ft³/min)</b>	0 to 9999		n/a		n/a	
<b>Temperature Ranges</b>	n/a		-4 to 212°F (-20 to 100°C)		-4 to 176°F (-20 to 80°C) *with HTP202	
<b>Accuracy</b>	n/a		+/- (0.3°C + 0.2% of reading in °C)		+/- (0.3°C + 0.2% of reading in °C)	
<b>Relative Humidity Ranges</b>	n/a		n/a		5.0 to 95.0 %RH	
<b>Accuracy</b>	n/a		n/a		+/- 2.0 %RH	
<b>Power Supply</b>	3 x AA Batteries		3 x AA Batteries		3 x AA Batteries	
<b>Main Unit Dimensions</b>	W3.2" x H6.5" x D1.5"		W3.2" x H6.5" x D1.5"		W3.2" x H6.5" x D1.5"	
<b>Weight</b>	0.95 lbs (430 g)		0.95 lbs (430 g)		1.1 lbs (500 g)	

### Air Velocity Probes

Model	AP275	APT275	AP100	APT100
<b>Air Velocity</b>	2.75" Head		1.00" Head	
ft/min	40 to 7800		300 to 6890	
m/s	0.2 to 40.0		1.5 to 35.0	
<b>Accuracy</b>	+/- (1.0% reading + 1 digit)		+/- 0.50% FS + 0.75% reading + 1 digit	
<b>Temperature</b>	n/a		n/a	
°F	n/a		n/a	
°C	n/a		n/a	
<b>Accuracy</b>	+/- (0.3°C + 0.2% of reading in °C)		+/- (0.3°C + 0.2% of reading in °C)	

### Humidity & Temp. Probe

Model	HTP202
<b>Relative Humidity</b>	
Range	5.0 to 95.0 %RH
Resolution	0.1 %RH
Accuracy	+/- 2.0 %RH
<b>Temperature</b>	
°F	-4 to 176
°C	-20 to 80
<b>Accuracy</b>	+/- (0.3°C + 0.2% of reading in °C)

### Thermal probes option

Each temperature probe utilizes a high-quality, Pt100 resistance element. Accuracy according to IEC 751 class B. Handles are 100 mm long and are rated to 90°C. Probes have coiled polyurethane cables which are 1000 mm long.



### RTD Temperature Probes

Model	PT211	PT212	PT213	PT216
<b>Type</b>	Immersion RTD Temperature Probe	Air RTD Temperature Probe	Surface RTD Temperature Probe	Penetration RTD Temperature Probe
<b>Temperature</b>				
°F	Up to 1112	Up to 1112	Up to 572	Up to 1112
°C	Up to 600	Up to 600	Up to 300	Up to 600
<b>Response Time</b>	7 seconds	5 seconds	4 seconds	7 seconds
<b>Dimensions</b>	130mm long x 3mm diameter	130mm long x 3mm diameter	130mm long x 3mm diameter	130mm long x 3mm diameter

### Accessories

- PT211** Immersion RTD Temperature Probe
- PT212** Air RTD Temperature Probe
- PT213** Surface RTD Temperature Probe
- PT216** Penetration RTD Temperature Probe
- 10215:** Analog Output
- 10216:** USB Output
- 10217:** RS232C Output
- 10227:** Splash-proof Rubber Boot and Seal
- 10195:** 10' Rigid Extension Rod
- 10196:** 10' Flexible Extension Rod
- 10052:** 5' Cable for Air Probe\*
- 10059:** 5' Cable for Air & Temp. Probe\*
- 6004:** Carrying Case

\* Additional cable lengths available

# TABmaster™ Capture Hood Model 6710

## A solution for airflow testing and balancing

The new Kanomax TABmaster™ is the perfect tool for accurate supply and return airflow measurements. Interchangeable hoods make it a snap to sample the air for any duct size. The unit is lightweight and easy to handle. The full color screen can be tilted so it's always at the optimal viewing angle regardless of height.

### Features:

- 23 to 2500 cfm (40 to 4250 m<sup>3</sup>/h) range
- Simultaneously measures and displays air flow, temperature and humidity
- Displays the velocity as well as the direction of the airflow
- Store up to 3,000 Measurements
- Advanced storage feature allows you to store multiple measurements under a single ID#
- Built-in back pressure compensation ensures accuracy for large volumetric flow measurements
- Includes: standard hood, carrying case, AA batteries, PC communication cable, data processing software, user manual, and calibration certificate

### Applications:

- HVAC testing, adjusting and balancing
- Air volumetric flow measurements through registers, diffusers and grilles
- Direct readout at supply and return airflow
- Air velocity measurement in the duct
- Check filter fouling by measuring differential pressure

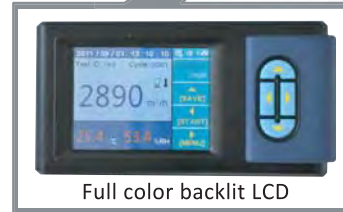

Screen tilts with one button



Specifications	
Model	6710
Airflow Range	23 to 2500 CFM (40 to 4250 m <sup>3</sup> /h)
Accuracy	+/-3% of reading +/- 10 m <sup>3</sup> /h
Resolution	1m <sup>3</sup> /h
Temperature Range	32 to 122°F (0 to 50°C)
Accuracy	+/-1.0°F (0.5°C)
Resolution	0.1°C
Humidity Range	0 to 100%RH
Accuracy	+/-3.0%RH
Resolution	0.1%RH
Interface	USB
Datalogging	Up to 3000 measurements
Power Supply	AA batteries or AC adapter
Hood Dimensions	Standard: 2x2ft (610x610mm) Option: 1x4ft (305x1220mm), 2x4ft(610x1220mm) 3x2ft (915x610mm), 3x3ft (915x915mm)
Weight	7.9 lbs (3.6 kg)

### Accessories

- 6710-01: AC Adapter
- 6710-02: Spare Hood 2x2 ft (610x610mm)
- 6710-03: Spare Hood 1x4 ft (305x1220mm)
- 6710-04: Spare Hood 2x4 ft (610x1220mm)
- 6710-05: Spare Hood 3x2 ft (915x610mm)
- 6710-06: Spare Hood 3x3 ft (915x915mm)
- 6710-10: Capture Hood Stand



New portable stand: extends up to 6.9' from top to base



# Anemomaster™ Model 6162

## High Temperature Anemometer

### Features:

- Air velocity and temperature measurements in 932°F (500°C) environments
- Record and recall MAX / MIN / AVG, Timing graph display
- Store up to 999 measurements
- RS232C interface, analog output, and remote control terminal equipped
- Includes shoulder strap, AC adapter, 2 pcs. analog output cable, and 6 pcs. C cell batteries

High temperature measuring solution requires Model 6162 with optional high temperature probe (0203, 0204 or 0205)

- The Model 0203 includes probe with 4.9 ft (1.5m) cable, 5m probe connection cable, probe case, and NIST Certificate
- The Model 0204 includes probe with 7.6 ft (2.3m) cable, 5m probe connection cable, probe case, and NIST Certificate
- The Model 0205 includes probe with 7.6 ft (2.3m) cable, 10m probe connection cable, probe case, and NIST Certificate



### Main Unit Specifications

Model	6162
Air Velocity Ranges	Varies by Probe, See below for Probe Specifications
Accuracy	+/- (3% of Full Scale)
Temperature Ranges	Varies by Probe, See below for Probe Specifications
Accuracy	+/- (1% of reading + 1°C)
Interface	RS232C
Datalogging	999 measurements
Analog Output	0 to 1 V
Remote Terminal	START/STOP Key
Power Supply	6 x C cell Batteries or AC Adapter
Dimensions	W8.7" x H3.3" x D5.9"
Weight	4.0 lbs (1.8 kg)

### Probe Specifications

Model	0203	0204 / 0205
Air Velocity Measuring Range	Temp. Range	
	32 to 212°F	40 to 9840 fpm (0.2 to 50.0 m/s)
	212 to 392°F	80 to 9840 fpm (0.4 to 50.0 m/s)
	392 to 572°F	n/a
	572 to 752°F	n/a
Accuracy	+/- 3% F.S.	
Temperature Measuring Range	32 to 392°F (0 to 200°C)	32 to 932°F (0 to 500°C)
	Accuracy	+/- 1% of reading
Dimensions / Weight	∅ 11 x 200mm (∅ 0.4" x 7.8")	0204 ∅ 14 x 1000mm (∅ 0.6" x 39.4") 1.1 lbs (500 g)
	0.4 lbs (200 g)	0205 ∅ 14 x 500mm (∅ 0.6" x 19.7") 0.4 lbs (200 g)
Probe Cables	Teflon Coating	
Heat-resistance	392°F (200°C)	
Probe Connection Cable	Vinyl Coating	
Heat-resistance	176°F (80°C)	

### Accessories

- 0203:** Probe for Middle Temperature
- 0204:** Probe for High Temperature (Long)
- 0205:** Probe for High Temperature (Short)
- 6162-03:** Extension Rod for 0203
- 6162-04:** Extension Rod for 0204/0205
- 6162-05:** Probe Compression fitting for 0203
- 6162-06:** Probe Compression fitting for 0204/0205
- 6162-07:** Communication Cable to PC
- S600-00:** Data Processing Software
- 6511-09:** Printer Cable for DPU-S245
- DPU-S245:** Portable Thermal Printer
- TP-202L:** Rolled Printer Paper (10 rolls)

\*Optional probe cable length up to 40m is available

### Probe Dimensions

\*Length in mm

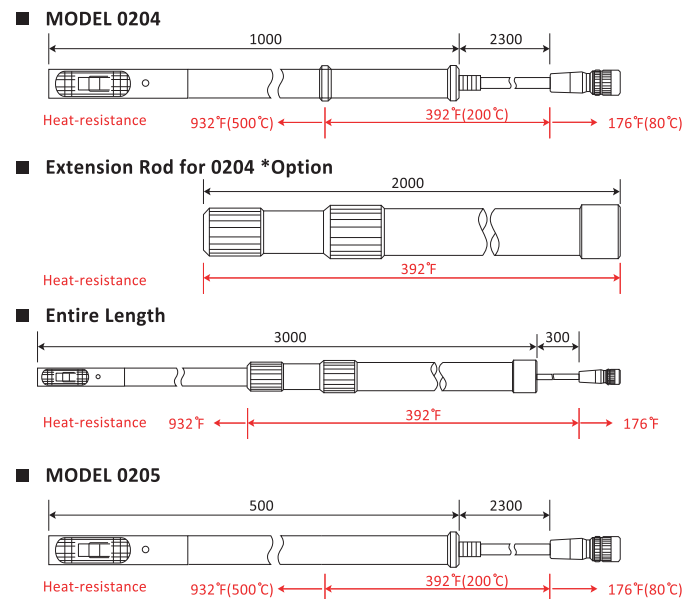
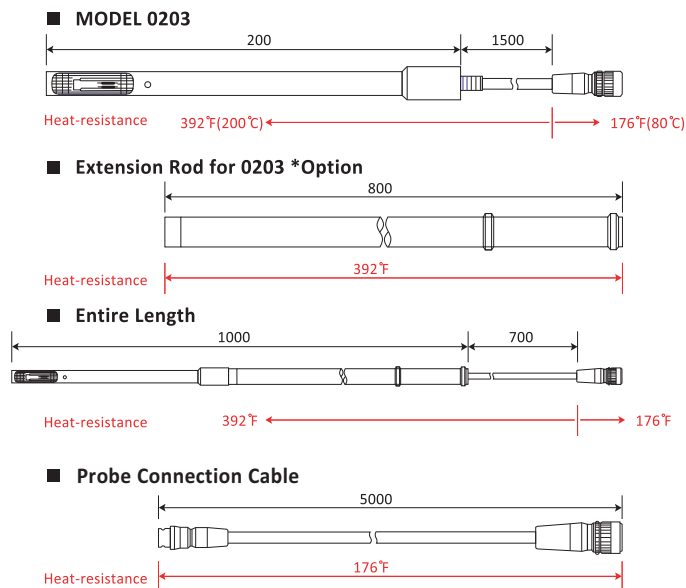

## Pitot Static Tube

### Stainless Steel Construction Pitot Tubes

The unique ellipsoidal nose form results in exceptional accuracy, insensitivity to errors in alignment and elimination of the need for calibration curves. Constructed from stainless steel, tubes can be as small as 2.3 mm in diameter yet scaled up to 4 m in length.

#### Features:

- Totally compatible with manometers, pressure gauges and pressure transmitters
- Ideal for measurement of air velocity in hostile environments
- Integral thermocouple for combined pressure and temperature sensing
- Can be used in permanent position when fitted with gland
- S-Type for limited access and adverse conditions

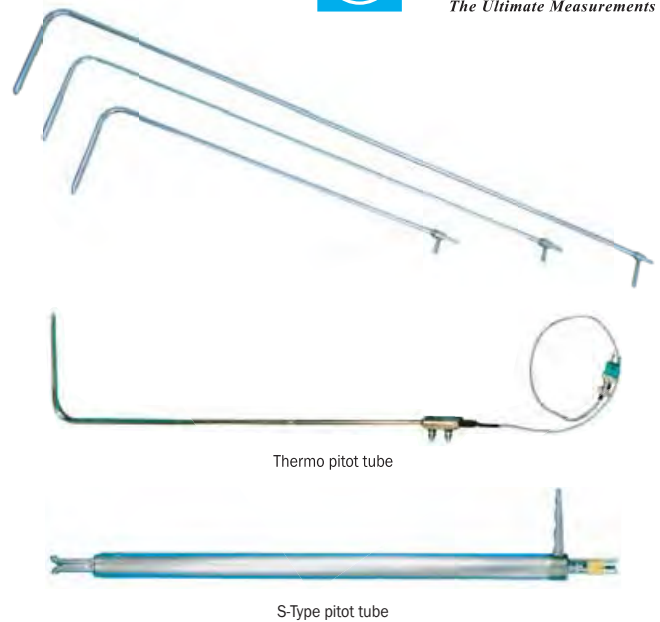

#### Specifications:

Easy Fit Ellipsoidal Pitot Tube											
Overall Length (m)	0.2	0.3	0.3	0.5	0.5	0.75	0.75	1.0	1.0	1.25	1.25
Tube Diameter (mm)	2.3	4	4	8	8	8	8	8	8	9.5	9.5
Head Diameter (mm)	2.3	4	4	8	8	8	8	8	8	9.5	9.5
Gland (inch)			1/4"		3/8"		3/8"		3/8"		1/2"

Classic Ellipsoidal Pitot Tube								
Overall Length (m)	1.83	2.13	2.44	2.74	1.0	1.22	1.52	1.83
Tube Diameter (mm)	12.7	19	19	19	8	9.5	9.5	12.7
Head Diameter (mm)	9.5	9.5	9.5	9.5	8	9.5	9.5	9.5
Gland (inch)					3/8"	1/2"	1/2"	1/2"

Pitot with K-Type Thermocouple		
Overall Length (m)	0.3	1.0
Tube Diameter (mm)	4	8
Head Diameter (mm)	4	8

S-Type Pitot Tube				
Overall Length (m)	0.7	1.2	2.2	3.2

## Handheld Micromanometer MP200

### Multi-function Micromanometer

Handheld Micromanometer MP200 is an ideal tool for pressure and airflow measurements. It is compatible with pitot tube and flow grids. It simultaneously measures and displays pressure, air velocity, and flow rate.



#### Features:

- Simultaneously measures and displays pressure, air velocity, and airflow
- Store up to 8000 measurements
- Optional data processing software is available for data transfer

Specifications	
<b>Pressure Measurement</b>	
<b>Range</b>	<b>Accuracy</b>
-500 to 500 Pa	0.2% of reading +/- 0.8 Pa (+/- 100 Pa) 0.2% of reading +/- 1.5 Pa (beyond +/- 100 Pa)
-2500 to 2500 Pa	0.2% of reading +/- 2 Pa
-10000 to 10000 Pa	0.2% of reading +/- 10 Pa
<b>Units</b>	Pa, mmHg <sub>2</sub> O, In WG, mbar, hPa, mmHg, DaPa, kPa
<b>Air Velocity Measurement (with Pitot tube)</b>	
<b>Range</b>	<b>Accuracy</b>
2 to 5 m/s	+/- 0.3 m/s
5.1 to 10 m/s	0.5% of reading +/- 0.2 m/s
<b>Units</b>	m/s, ft/min, Km/h, m/h
<b>Airflow Measurement (with Pitot tube)</b>	
<b>Range</b>	<b>Accuracy</b>
0 to 99999 m <sup>3</sup> /h	0.2% of reading +/- 1% PE
<b>Units</b>	m <sup>3</sup> /h, cf/min, l/s, m <sup>3</sup> /s
<b>PC Interface</b>	USB or RF
<b>Datalogging</b>	Data storage up to 8000 measurements (PC communication with optional data processing software)
<b>Power Supply</b>	4 x AA batteries or AC adapter
<b>Weight</b>	0.7 lbs

# Wilson Flow Grids

## For Accurate In-Duct Volume Flow Measurements

Permanent monitor for round and rectangular ducts accurately senses air flow rates. Flow grids will transmit a comparable and repeatable differential pressure proportional to the average air flow, however turbulent the in-duct conditions and with no moving parts long term reliability is assured.

### Features:

- Choice of standard (rectangular) and radial grid formats to best suit various applications
- Suitable for clean air velocities between 1.5 and 30 m/s (6000 fpm).
- Standard version suitable up to 80 °C with all-welded units up to 450 °C.
- Perfect for HVAC, building automation systems, process control, R&D, and wind tunnel air flow monitoring.



### Standard sizes

Rectangular Grids		
Type A 6.4mm (1/4") diameter tube	Manifold length (mm)	100 to 450
	Pressure Tube length (mm)	150 to 450
Type B 12.7mm (1/2") diameter tube	Manifold length (mm)	250 to 650
	Pressure Tube length (mm)	350 to 1200
Type C 25.4mm (1") diameter tube	Manifold length (mm)	750 to 1000
	Pressure Tube length (mm)	800 to 2000

Radial Grids		
Type A 6.4mm (1/4") diameter tube	Diameter (mm)	100 to 500
Type B 12.7mm (1/2") diameter tube	Diameter (mm)	500 to 1100
Type C 25.4mm (1") diameter tube	Diameter (mm)	1100 to 2500

\*Custom flow measuring station built to customer's specification upon request

### How it works

The Wilson Flow Grid consists of a row of tubes with closed ends, parallel to each other and forming an open fence across the duct at right angles to the axis. Some of the tubes are perforated with small holes facing upstream which sense total pressure, whilst other tubes have holes on the downstream side to sense throat static pressure. The spacing of these holes conforms approximately with the Log Tchebycheff distribution for direct summing and averaging. The upstream and downstream tubes are connected to separate manifolds which thus provide two average pressure signals. The pressure difference between the manifolds constitutes the output signal. The increase in velocity between the tubes results in a corresponding reduction in static pressure which is sampled by the downstream holes. The forward facing holes sample the duct total pressure. These two pressure signals form the differential output.

To complete the system a transducer is required to convert the differential signal into a usable reading. The reading will be in pressure units from which velocity or volume flow can be calculated.

\*Pressure transducers are available from Kanomax.

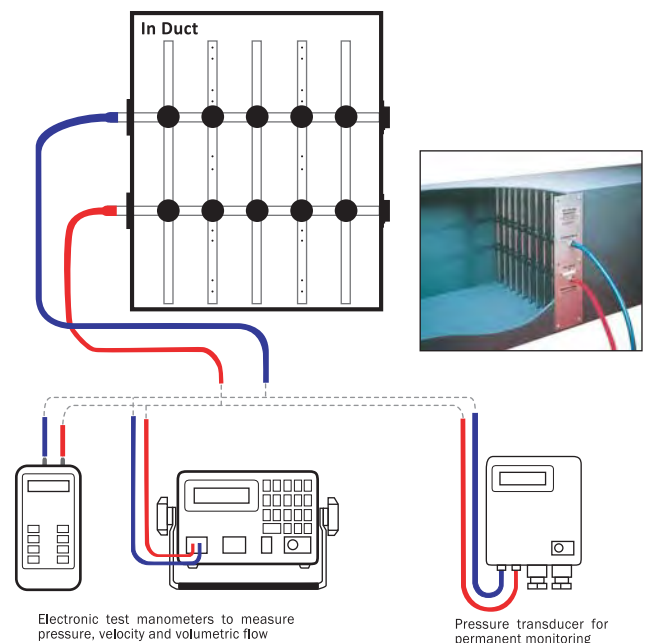

# Multi-Channel Measuring Instruments

Multi-Channel Anemometers

Multi-Channel Anemometers

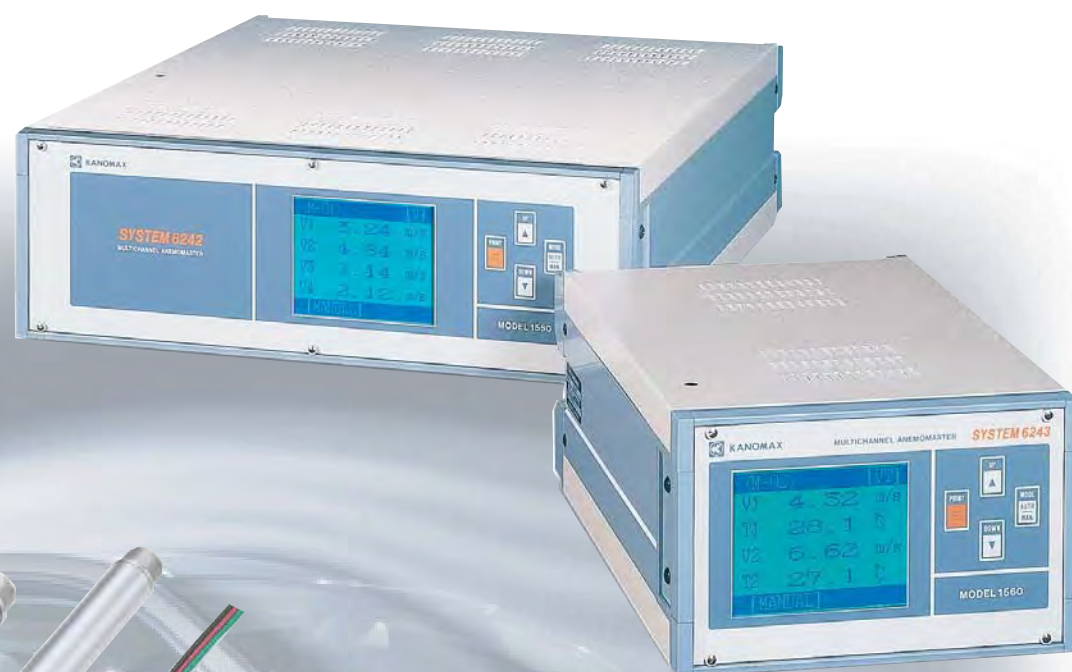

**Variety of probes for many applications**



## Airflow Transducer Model 6332 / 6332D

Compact design Airflow Transducer, fits into small spaces

- 10 interchangeable probes are available for various applications
- Easy probe replacement without recalibration of the main unit
- Selectable output options: 0 to 5 V or 4 to 20 mA



## 4-Channel Anemomaster™ Model 1570

Compact design 4-channel unit with compatible probes

- 10 interchangeable probes are available for various multi-channel applications
- Simultaneous measurements of 4 channels of air velocity
- Software allows real-time measurements of air velocity and airflow in 4 channels
- The Model 1570 includes data processing software, RS232C cable, power cable, and 2 pcs. fuse



## Multi-Channel Anemomaster™ Model 1550 / 1560

Up to 320 points multi-measurement system with a variety of probes

- System can be scaled up with modules and probes
- 3 types of probes are available
- 4 types of modules are available
- The chassis may be cascaded up to 5 units via RS232C
- Multi-channel Anemomaster includes RS232C cable, printer cable, power cable, and 2 pcs. fuse

### Main Unit Specifications

Model	6332/6332D	1570	1550 / 1560
Probe Compatibility	V Probe	V Probe	V Probe / VT Probe / VTH Probe
Air Velocity Ranges	20 to 9840 fpm (0.10 to 50.0 m/s)	20 to 9840 fpm (0.10 to 50.0 m/s)	20 to 9840 fpm (0.10 to 50.0 m/s)
Temperature Ranges	n/a	n/a	32 to 212°F (0 to 100°C)
Relative Humidity Ranges	n/a	n/a	5.0 to 95.0 %RH
PC Communication	n/a	Data Processing Software	Data Processing Software
Interface	n/a	RS232C	RS232C, Centronics, GP-IB
Analog Output	DC 4 to 20mA or DC 0 to 5V	0 to 5 V	0 to 5 V
Power Supply	DC or AC	AC	AC
Dimensions	W3.1" x H5.0" x D1.2"	W10.2" x H2.8" x D7.9"	Model 1550: W19.6" x H5.5" x D16.9" Model 1560: W8.9" x H5.5" x D12.8"
Weight	0.7 lbs (320 g)	5.7 lbs (2.6 kg)	Model 1550: 22 lbs (10 kg) Model 1560: 11 lbs (5 kg)

# Airflow Transducer Model 6332 / 6332D

## Features:

- Smart probe technology: easy probe replacement without recalibration of the main unit
- Selectable output options: 0 to 5 V or 4 to 20 mA



### Main Unit Specifications

Model	6332	6332D
Display	—	○
Air Velocity Ranges	Varies by Probe, See below for Probe Specifications	
Accuracy	+/- 3% of reading	
Analog Output	DC 4 to 20mA or DC 0 to 5V	
Power Consumption	Approx. 2.0 W	
Power Supply	DC 12 to 24V or AC 80 to 240V	
Dimensions	W3.1" x H5.0" x D1.2"	
Weight	0.7 lbs (320 g)	

# 4-Channel Anemomaster™ Model 1570

## Features:

- Simultaneous measurements of 4 channels of air velocity; easy to switch over each channel display
- Software allows real-time measurements of air velocity and airflow in 4 channels
- The Model 1570 includes data processing software, RS232C cable, power cable, and 2 pc. fuse



### Main Unit Specifications

Model	1570
Air Velocity Ranges	Varies by Probe, See Probe Specifications
Resolution	0.01 m/s
Interface	RS232C
Analog Output	0 to 5 V
Power Supply	AC 85 to 265 V
Dimensions	W10.2" x H2.8" x D7.9"
Weight	5.7 lbs (2.6 kg)

## Compatible Probes

### ■ Air Velocity Probes (V probes)

Probe Specifications	0962-00	0963-00	0965-00	0965-01
Model	0962-00	0963-00	0965-00	0965-01
Probe Type	Uni-Directional	Uni-Directional	Omni-Directional (with horn)	Omni-Directional
Air Velocity	20 to 9840 fpm (0.10 to 50.0 m/s)	20 to 9840 fpm (0.10 to 50.0 m/s)	20 to 9840 fpm (0.10 to 25.0 m/s)	20 to 9840 fpm (0.10 to 25.0 m/s)

Probe Specifications	0965-03	0965-04	0965-07	0965-08
Model	0965-03	0965-04	0965-07	0965-08
Probe Type	Omni-Directional	Omni-Directional	Omni-Directional	Omni-Directional
Air Velocity	20 to 4920 fpm (0.1 to 25.0 m/s)	20 to 4920 fpm (0.1 to 25.0 m/s)	20 to 4920 fpm (0.1 to 25.0 m/s)	20 to 4920 fpm (0.1 to 25.0 m/s)

# Multi-Channel Anemomaster Model 1550/1560

## Features:

- The multi-channel Anemomaster is composed of chassis, module, and probe. The Model 1550 (chassis) holds 16 modules and the Model 1560 holds 6 modules
- The chassis may be cascaded up to 5 units  
5 units of the Model 1550 may hold 320 channels of air velocity sensors
- 3 types of probes are available  
Air velocity probe (V probe)  
Air velocity / Temperature probe (VT probe)  
And air velocity / Temperature / Humidity probe (VTH probe)
- 4 types of modules are available  
4 channel air velocity module  
2 channel air velocity / temperature module  
1 channel air velocity / temperature / humidity module  
Analog output module
- Multi-channel Anemomaster includes RS232C cable, printer cable, power cable, and 2 pcs. fuse



Multi-Channel Anemometers

## Accessories

- 1500-01:** RS232C for Cascade Connection
- 1500-02:** GP-IB Output
- 1500-03:** Ring Guard for Probe Protection
- 1504-02:** Cable for V Module (10m)\*
- 1511-01:** Cable for VT Module (10m)\*
- 1512-01:** Cable for VTH Module (10m)
- S620-00:** Data Processing Software (for Windows)

\* Additional cable lengths available

## Main Unit Specifications

Model	1550	1560
<b>Air Velocity Ranges</b>	Varies by Probe, See below for Probe Specifications	
Resolution	0.01 m/s	
<b>Temperature Ranges</b>	Varies by Probe, See below for Probe Specifications	
Resolution	0.1°C	
<b>Relative Humidity Ranges</b>	Varies by Probe, See below for Probe Specifications	
Resolution	0.1%RH	
<b>Interface</b>	RS232C for PC connection	
	RS232C for Cascade *Option	
	Centronics for Printer Output	
	GP-IB *Option	
<b>Analog Output</b>	0 to 5 V *Option with D/A Module	
<b>Power Supply</b>	AC Adapter	
<b>Dimensions</b>	W19.6" x H5.5" x D16.9"	W8.9" x H5.5" x D12.8"
<b>Weight</b>	22 lbs (10 kg)	11 lbs (5 kg)

## Air Velocity • Temperature • Humidity Probes (VT / VTH Probes)

Probe Specifications	0962-21	0963-21	0965-21	0963-31	0965-31
<b>Model</b>	0962-21	0963-21	0965-21	0963-31	0965-31
<b>Probe Type</b>	Uni-Directional	Uni-Directional	Omni-Directional	Uni-Directional	Omni-Directional
<b>Air Velocity</b>	20 to 9840 fpm (0.10 to 50.0 m/s)	20 to 9840 fpm (0.10 to 50.0 m/s)	20 to 9840 fpm (0.10 to 50.0 m/s)	20 to 9840 fpm (0.10 to 50.0 m/s)	20 to 9840 fpm (0.10 to 50.0 m/s)
<b>Temperature Ranges</b>	32 to 212°F (0 to 100°C)	32 to 212°F (0 to 100°C)	32 to 212°F (0 to 100°C)	32 to 140°F (0 to 60°C)	32 to 140°F (0 to 60°C)
<b>Relative Humidity Ranges</b>	n/a	n/a	n/a	5.0 to 95.0 %RH	5.0 to 95.0 %RH

## Modules

Specifications	1504	1511	1512	1510
<b>Model</b>	1504 V Module	1511 VT Module	1512 VTH Module	1510 D/A Module
<b>Module Type</b>	Air Velocity	Air Velocity, Temp.	Air Velocity, Temp., Humidity	Analog Output
<b># of Channel</b>	4	2	1	1



Model 1560 has 6 slots for modules

■ Applications



Hospitals and Elderly Care Facilities Monitor



Green building rating system  
IEQ performance testing



Indoor Air Quality Investigation

# ***Indoor Air Quality Monitors***

***Ventilation Testing***

***Thermal Comfort Control***

***Occupational Health Control***

***Monitoring Toxic Gas***



# Handheld IAQ Monitor Model 2211

## Multi-Function Indoor Air Quality Monitor

### Features:

- Simultaneous measurements of CO, CO<sub>2</sub>, Temperature, and Relative humidity
- Calculates Dew point, Wet bulb temperature, Absolute humidity, Humidity Ratio, and % Outside Air
- Store up to 1500 measurements
- Easy user self calibration
- Easy replacement of probe
- PC interface with RS232C or USB and software for real-time measurements and downloading data to your PC
- Complete with probe with 79 in (2m) cable, probe stand, calibration cap & connection tube, data processing software, RS232C cable, USB to serial adapter, 6 pcs. AA batteries, carrying case, and NIST-Traceable calibration certificate



Software Included

Specifications	
Model	2211
Carbon Monoxide (CO)	0 to 500 ppm
Accuracy	+/- 3% of reading
Carbon Dioxide (CO <sub>2</sub> )	0 to 5000 ppm
Accuracy	+/- 3% of reading
Temperature Ranges	-4 to 140°F (-20 to 60°C)
Accuracy	+/- 1.0°F (0.5°C)
Relative Humidity Ranges	2.0 to 98.0 %RH
Accuracy	+/- 2% of reading
Interface	RS232C
Datalogging	1500 measurements
Analog Output	0 to 1 V *Option
Power Supply	6 x AA Batteries or AC Adapter
Dimensions	W3.4" x H7.4" x D1.6"
Weight	0.9 lbs (400 g)

### Accessories

- 6113-02: AC Adaptor  
 2211-09: Analog Output  
 DPU-S245: Portable Thermal Printer  
 6000-03: Printer Cable for DPU-S245  
 TP-202L: Rolled Printer Paper (10 rolls)

# Thermohygrometer Model 6841

## Palm Size Indoor Environmental Meter

### Features:

- Simultaneous measurements of Relative humidity and Temperature
- Display switchable in °F and °C for air temperature
- Lightweight, Palm Size Design
- The Model 6841 includes 4 pc. AA batteries

Specifications	
Model	6841
Temperature Ranges	-4 to 113°F (-20 to 45°C)
Accuracy	+/- 0.9°F (0.5°C)
Relative Humidity Ranges	5.0 to 95.0 %RH
Accuracy	+/- 3 %RH
Power Supply	4 x AA Batteries
Dimensions	W2.4" x H4.7" x D1.3"
Weight	0.4 lbs (180 g)



### Accessories

- A004-02: Hard Carrying Case

# Handheld Gas Monitors

CO, CO<sub>2</sub>, Ammonia, Ozone, VOC etc. More than 30 gases



Multi-gas sensor heads are available for IAQ survey applications

## Features:

- Simultaneous measurements of gas concentration, temperature, and humidity
- The S200 is a simple, easy-to-use, low-cost monitor
- The S300 has an on-board alarm and analog output
- The S500 has a data logging function and RS232C interface for PC communication
- The Remote Sensor Head Adaptor Kit is available (It is designed to allow the sensor head to be located up to 46 ft (14 m) away from the monitor)

Gas Monitors

Specifications	S200	S205	S300	S305	S500	S505
Model	S200	S205	S300	S305	S500	S505
Measurement Units	ppm or mg/m <sup>3</sup>	ppm or mg/m <sup>3</sup>	ppm or mg/m <sup>3</sup>	ppm or mg/m <sup>3</sup>	ppm or mg/m <sup>3</sup>	ppm or mg/m <sup>3</sup>
T/H* Sensor	—	○	—	○	—	○
On-board alarm	—	—	○	○	○	○
Remote Sensor	○	○	○	○	○	○
Datalogging	—	—	—	—	4,300 measurements	3,400 measurements
Interface	—	—	—	—	RS232C	RS232C
Analog Output	—	—	0 to 5 V	0 to 5 V	0 to 5 V	0 to 5 V
Power supply	9.6V Battery / 12 VDC	9.6V Battery / 12 VDC	9.6V Battery / 12 VDC	9.6V Battery / 12 VDC	9.6V Battery / 12 VDC	9.6V Battery / 12 VDC
Dimensions	W7.4" x H4.8" x D2.1"	W7.4" x H4.8" x D2.1"	W7.4" x H4.8" x D2.1"	W7.4" x H4.8" x D2.1"	W7.4" x H4.8" x D2.1"	W7.4" x H4.8" x D2.1"
Weight	1.0 lbs (460 g)	1.0 lbs (460 g)	1.0 lbs (460 g)	1.0 lbs (460 g)	1.0 lbs (460 g)	1.0 lbs (460 g)

\* Temperature and Humidity

## Gas Sensor Heads

### Gas Sensors Specifications

Gas Sensor Heads	Range (ppm)	Accuracy	Resolution
Ammonia	0 - 100	+/- 5 ppm	0.1 ppm
Ammonia (leak)	0 - 1000	+/- 15%	1 ppm
Carbon monoxide	0 - 100	+/- 5 ppm	0.1 ppm
Carbon monoxide	0 - 1000	+/- 10%	1 ppm
Carbon dioxide	0 - 2000	+/- 40 ppm + 3%	10 ppm
Carbon dioxide	0 - 5000	+/- 150 ppm + 5%	10 ppm
Hydrogen	0 - 5000	+/- 10%	1 ppm
Hydrogen sulphide	0 - 10	+/- 0.5 ppm	0.01 ppm
Methane	0 - 9999	+/- 15%	1 ppm
Ozone	0 - 0.150	+/- 0.005 ppm	0.001 ppm
Ozone	0 - 0.500	+/- 0.008 ppm	0.001 ppm
Nitrogen dioxide	0 - 1	+/- 0.001 ppm	0.001 ppm
NMHC 3,4	0 - 25	+/- 10%	0.1 ppm
Perchloroethylene	0 - 200	+/- 5 ppm	1 ppm
Sulphur dioxide	0 - 10	+/- 0.5 ppm	0.01 ppm
<b>Formaldehyde</b>	<b>0 - 10</b>	<b>+/- 0.05 ppm</b>	<b>0.01 ppm</b>
VOC	0 - 25	+/- 10%	0.1 ppm
VOC	0 - 500	+/- 10%	1 ppm
VOC PID	0 - 20	+/- 10%	0.01 ppm
VOC PID	0 - 1000	+/- 10%	0.1 ppm

**New!**

Multi-Gas Sensor Heads	Sensor	Range (ppm)	Accuracy	Resolution
MS1	CO <sub>2</sub>	0-2000	+/- 40 ppm + 3%	1 ppm
	CO	0-100	+/- 10%	0.1 ppm
MS2	CO <sub>2</sub>	0-2000	+/- 40 ppm + 3%	1 ppm
	CO	0-100	+/- 10%	0.1 ppm
	VOC (PID)	0-25	+/- 10%	0.01 ppm

\* Other specific concentrations available on request

## Features:

- The gas monitor is fully compatible with all gas sensors
- Sensor heads for handheld units are interchangeable without recalibration of main unit



## Accessories

- R10:** Remote Sensor Adapter with Cable
- R13:** Remote Sensor Adapter with Cable, Enclosure
- R31:** Replacement Battery
- R32:** Cigarette Lighter Adapter Battery Charger
- R33:** Wall Mount Bracket
- R40:** Carrying Case
- R52:** RS232 to USB Converter



# Indoor Air Quality Monitor IQM60

## Most IAQ Parameters Covered in This Single Unit

### Features:

- Multiple Gas measurements (up to 6 gases)
- Temperature and Humidity Sensors
- Particle Monitoring for PM 10, PM 2.5, PM 1, and TSP \*Optional
- All sensors are NIST traceable certified
- Large Internal Data Storage Capacity
- GSM Wireless Communication for remote monitoring \*Optional
- Standard IQM60 includes standard sensors (CO, CO2, Temperature, R/H), PC configuration and data logging software, RS232C to USB converter cable, and AC adapter



Software included



Main Unit Specifications	
<b>Model</b>	<b>IQM 60</b>
<b>Interface</b>	RS232 (Serial cable and USB adapter supplied)
<b>Data Storage</b>	Removable SD card 1GB
<b>Wireless Communication</b>	GSM modem *Option
<b>Power Supply</b>	AC adapter External Li-ion portable power station *Optional
<b>Dimensions</b>	W 10.9" x H 5.2" x D 9.3" (278 x 132 x 236 mm)
<b>Weight</b>	Approx. 11 lbs (5.0 kg)



IQM60 is able to offer the complete package for performing in-depth analysis and surveys of indoor air quality at airport lounges, shopping malls, offices, schools, and hospitals.

Gas Sensors Specifications				
Gas Sensor Modules	Sensor	Range (ppm)	Accuracy	Resolution
Ammonia	GSE	0 - 100	<+/- 10%	0.1 ppm
Carbon dioxide	NDIR	0 - 2,000	<40 ppm + 3%	1 ppm
Carbon dioxide	NDIR	0 - 5000	<150 ppm + 5%	1 ppm
Carbon monoxide	GSS	0 - 100	<+/- 5 ppm	0.1 ppm
Formaldehyde	GSE	0 - 10	<+/- 0.05 ppm	0.01 ppm
Non-methane hydrocarbon	GSS	0 - 25	<+/- 0.5 ppm	0.1 ppm
Hydrogen sulphide	GSS	0 - 10	<+/- 0.5 ppm	0.01 ppm
Nitrogen dioxide	GSE	0 - 0.200	<+/- 15%	0.001 ppm
Ozone	GSS	0 - 0.150	<+/- 0.005 ppm	0.001 ppm
Ozone	GSS	0 - 0.500	<+/- 0.008 ppm	0.001 ppm
Sulfur dioxide	GSE	0 - 10	<+/- 0.05 ppm	0.01 ppm
VOC isobutylene	GSS	0 - 25	<+/- 10%	0.1 ppm
VOC isobutylene	PID	0 - 20	<10%	0.01 ppm

### Optional Sensor Module

- IQMENG:** Ammonia sensor module
- IQMCD:** CO2 (0 - 2000ppm) sensor module
- IQMCE:** CO2 (0 - 5000ppm) sensor module
- IQMCN:** CO sensor module
- IQMVM:** VOC isobutylene sensor module
- IQMPD:** VOC PID isobutylene sensor module
- IQMEF:** Formaldehyde sensor module
- IQMVN:** Non Methane Hydrocarbon sensor module
- IQMHS:** Hydrogen sulphide sensor module
- IQMNW:** Nitrogen dioxide sensor module
- IQMUZ:** Ozone (0 - 150ppm) sensor module
- IQMLZ:** Ozone (0 - 500ppm) sensor module



Option Sensors Specifications			
Sensor	Range	Accuracy	Resolution
<b>Temperature</b>	-20 to 100°C	+/- 0.3C @ 25°C	0.1°C
<b>Humidity</b>	0 to 100%RH	+/- 2%RH @ 25°C	0.1%RH
<b>Particle Monitor</b>	Range	1 to 2000 µg/m³	
	Particle Size	0.1 to 10 µm	
	Precision	3 µg/m³	
	Accuracy	8% NIOSH 0600	
	LT Stability	5% of reading	
Cut Points	TSP, PM1, PM2.5, PM10		

### Optional Accessories

- IQMPM:** TSP Particulate Monitor
- IQMR1:** PM2.5 Cyclone
- IQMR2:** PM10 Cyclone
- IQMR3:** Replacement PID Lamp



TSP Particle Monitor

# Networked Gas Monitoring Systems

## Fixed Transmitters & Controllers

### Features:

- The gas sensors are able to measure concentrations of Ozone, Volatile Organic Compounds, Ammonia, Carbon Monoxide
- Each sensor head has its own identification (ID), which allows a "Daisy-Chain" network to be created utilizing either a computer system or Programmable Logic Controller (PLC)
- Networks of up to 256 individual monitors/transmitters can be created



Specifications	S905	S935	S945
Model	S905	S935	S945
Measuring Ranges	See Gas Sensors Specifications	See Gas Sensors Specifications	See Gas Sensors Specifications
T/H Sensor	○	○	○
Alarm Output	○	○	○
Analog Output	4 - 20 mA	4 - 20 mA and 12 to 24 V	4 - 20 mA and 12 to 24 V
Interface	RS485	RS485	RS485
Power supply	24 VDC	24 VDC	24 VDC
Enclosure size	2.5" x ø5.1"	W7.1" x H4.3" x D3.5"	W9.1" x H5.5" x D3.7"
Enclosure casing	Fibre reinforced plastic	Fibre reinforced polycarbonate	Fibre reinforced polycarbonate
Weight	850 g	850 g	1.1 kg

### PLC Specifications

Model	R1000 Series
Sensor Channels	Up to 12
Digital Alarm Inputs	Up to 10
Alarm & Control Relays	Up to 22
Analog Inputs	Up to 13
Analog & Control Outputs	Up to 6
Expansion I/O	Up to a maximum of 128 I/O
Data-storage	13,000 data points
Communication	Serial: RS232/ RS485 (Selectable) ModBus: Supports MODBUS protocol, Master/Slave
Power Supply	DC 24V
Dimensions	W3.78" x H3.78" x D2.52" (96 x 96 x 64 mm)

## Monitors Networked to a computer

### Features:

- Centralized control from the PC or decentralized control from individual monitors
- Specialized application specific software is available on request



## Monitors Networked to the R1000 PLC

### Features:

- Centralized control from the PLC or decentralized control from individual monitors
- Specialized application specific software is available on request





# Dif-Kit Tracer Gas Hardware

## Professional Fume Hood Diagnostic Tools

### Features:

- The ANSI/ASHRAE 110 test is a method of testing the performance of laboratory fume hoods. Kanomax Dif-Kit tracer gas hardware is ideal for use in performing the Tracer Gas test in accordance with ANSI/ASHRAE Standard 110-1995.
- Diffuser is made to the design and specifications of Standard drawing #110-83M
- The internal critical orifice ensures a flow rate of 4 liters per minute. Other orifice sizes can be inserted
- Test-Mannequin and the vapor analyzer for the tracer gas test are available
- Face velocity measurement data can be stored and downloaded with Anemometer
- Dif-Kit includes tracer gas diffuser, nozzle assembly, in-line flow meter, tank regulator, and 20 ft of tubing
- Test-mannequin includes lab coat and stand



ASHRAE 110 - 1995  
Performance Testing

### ■ Dif-Kit

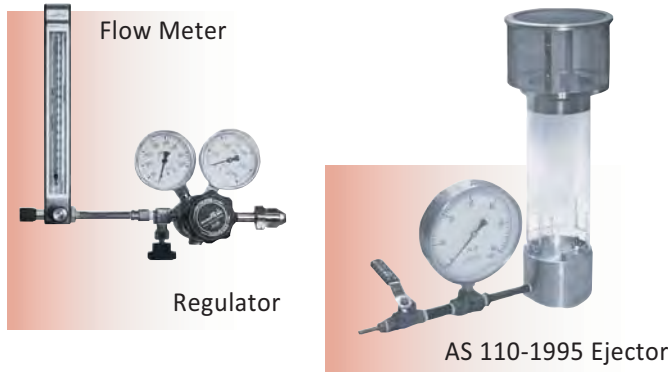

Specifications	
Model	Dif-Kit
Critical Orifice	4 liter per minute
Regulator	Dual Stage, Specialty Gas
Flow Meter	Calibrated 150 mm/200 psi, Glass Tube
Pressure Gage	0 to 60 psi

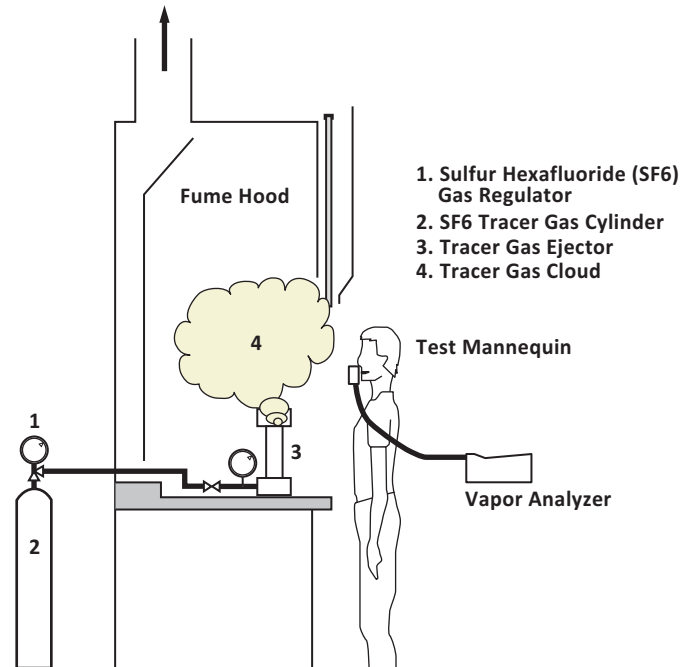

### ■ Vapor Analyzer

The Vapor Analyzer is factory calibrated for Sulfur Hexafluoride (SF6). Response time is less than 10 seconds to 90% response with a stable maximum concentration in less than 30 seconds.



Vapor Analyzer

Specifications	
Type	Single Beam Infrared Spectrophotometer
Sample Flow	10 liter per min (21.2 ft <sup>3</sup> /hr)
Sample Cell Volume	0.45 liters (0.0159 ft <sup>3</sup> )
Gas Purge	5 Cell Volumes for 99% purge of cell
Concentration Alarm	High & Low (selectable by user)
Interface	USB, RS232
Power Supply	NiMH battery or 120-220V AC
Dimensions	15 x 7.3 x 7.5 inches (381 x 185 x 191 mm)
Weight	18 lbs (8.2 kg)

■ Applications



Environmental noise measurement



Noise exposure measurement



Industrial vibration testing

Sound & Vibration Meters



# *Sound and Vibration Meters*



# Sound Level Meter Model 4431

## Precision Sound Level Meter with 0-dB Function

The new Kanomax sound level meter is designed to be compact, lightweight and easy to use. It complies with the type 2 ANSI S1.4 1983 standard, and has an innovative, unique 0-dB feature that eliminates the self-noise of the microphone. This technology extends the lower limit of the measurement range to lower than 0 dB-SPL.

### Features:

- Lightweight and compact design
- Equipped with highly sensitive electret condenser microphone
- Large 4 digit display with 0.1 dB resolution with backlighting and analog bar graph
- Add additional functions with the program cards
- Includes SD card for data storage, windshield, carrying case, AA batteries, hand strap, and calibration certificate



Optional program cards give you the flexibility to add additional functions as needed

Specifications	
<b>Model</b>	<b>4431</b>
<b>Parameters</b>	Lp, LA, LAeq, LAE, LAmx, LAmin, LAN, Lpeak, LAtm5
<b>Ranges</b>	A: 28 - 130 dB, Z 39 - 130 dB
<b>Weighting</b>	A, C and Z
<b>Time Response</b>	Fast or Slow
<b>Microphone</b>	TYPE 7146nl (-28dB, Stand-alone -26dB)
<b>Standards</b>	Type 1 (4432) or Type 2 (4431) standards for ANSI S1.4 1983, IEC 61672-1
<b>Power Supply</b>	4 AA Batteries or optional AC Adapter (Battery life: approx. 9 hours)
<b>Size &amp; Weight</b>	W3.4" x H12.9" x D1.9", Approx 1 lb.

### Accessories

- AC-1026:** AC adapter
- ACBC-0046-3:** Microphone Cable (3m)\*
- ACBC-0046-5:** Extension cable (5m)\*
- ACBC-0071:** BNC-Pin Cable
- ACNA-0038M:** Data processing software
- ACNA-0038:** Program card (1/1, 1/3 octave analyzer)
- ACNA-0038F:** Program card (FFT analyzer)
- ACNA-0038R:** Program card (Real Sound Recording)
- ACNA-0333:** Tripod

\*Additional cable lengths available

## Sound Calibrator

Sound Calibrator Model AC2127 implements stable and high-precision calibration by its feedback control function with temperature compensation.



Calibrator Specifications	
<b>Model</b>	<b>AC2127</b>
<b>Microphone sizes</b>	1 inch and 1/2 inch (1/2 inch microphone adapter is included)
<b>Sound Pressure Level</b>	94dB (+/-0.3dB)
<b>Frequency Level</b>	1000Hz (+/-0.1%)
<b>Standards</b>	IEC 60942: 2003 Class 1 JIS C1515: 2004 Class 1
<b>Power Supply</b>	2 x AA Batteries
<b>Size &amp; Weight</b>	W4.3" x H2.9" x D1.8", Approx 0.3 lb. (150g)

## Pistonphone

Model AC2124A is a standard sound source, which emits 124dB-SPL pure sine tone at 250Hz for calibration of sound level meter. This is used for precise calibration of sound level meter provided with 1-inch, 1/2-inch and 1/4-inch condenser microphones.



Pistonphone Specifications	
<b>Model</b>	<b>AC2124A</b>
<b>Sound Pressure Level</b>	124dB
<b>Accuracy</b>	+/- 0.2dB
<b>Frequency</b>	250Hz (+/- 2%)
<b>Power Supply</b>	4 x AA Batteries
<b>Size &amp; Weight</b>	∅ 1.5" x 8.8", Approx 1.7 lb. (800g)

# Sound Measurement Microphones

## Features:

- Wide frequency range: wide range of measurement from low-frequency to ultrasonic frequency (1Hz to 200 kHz) is possible.
- Wide dynamic range: measurement of high sound pressure level up to 170dB is possible.
- Pre-amplifier integrated microphone: it is also possible to connect directly to an analyzer by using a BNC cable.
- High sensitivity and certain measurement: it is possible to connect directly to analyzer such as an FFT and is easy to measure with low sound pressure levels.

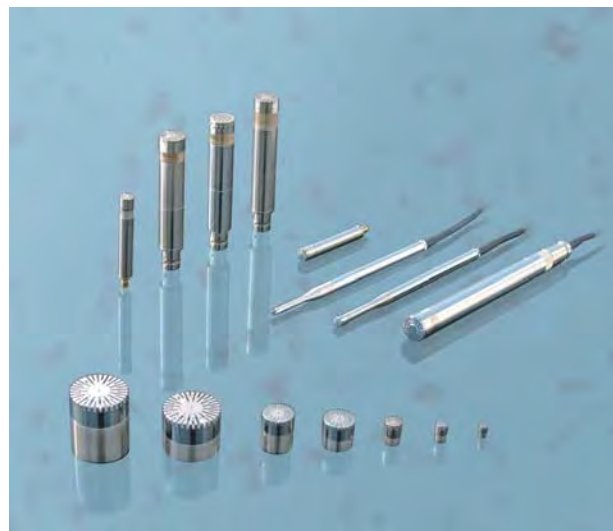

## Pre-amplifier integrated microphone

The pre-amplifier integrated microphone is compatible with IEPE (Integrated Electronic Piezoelectric Microphone) and can be connected directly to an FFT analyzer or other analyzers, enabling measurements with a highly accurate resolution at low cost. Long-term stability is accomplished by an accelerated aging process under 360°C.

Specifications											
	Model	4156N	4158N	4160N	4152N	4153N	7146	7147A	7312	7313	
Nominal Diameter	1/4 inch					1/2 inch					
Release Voltage	-56dB (1.6mV/Pa)	-48dB (4.0mV/Pa)				-32dB (25.1mV/Pa)			-26dB (50.0mV/Pa)	-36dB (15.8mV/Pa)	-38dB (12.5mV/Pa)
Pressure Sensitivity	-58dB +/- 3dB	-50dB +/- 3dB	-40dB +/- 3dB			-33dB +/- 3dB			-27dB +/- 2dB	-37dB +/- 2dB	-39dB +/- 2dB
Polarization voltage	0V										
Frequency Characteristics	20Hz to 40kHz	20Hz to 100kHz	20Hz to 10kHz	20Hz to 20kHz	20Hz to 10kHz	20Hz to 20kHz	20Hz to 10kHz	20Hz to 40kHz	20Hz to 20kHz		
Maximum sound pressure level	168dB	150dB	130dB	140dB		135dB		140dB			
Self-noise level	45dB	23dB		18dB		17dB		20dB			
Temperature coefficient	<0.01dB/°C	<0.009dB/°C	<0.7dB/°C	<0.01dB/°C		<0.009dB/°C					
Power supply and voltage	DC15 to 28V										
Constant current	0.5 to 4mA										
Connector	SMB connector					BNC connector					
Dimensions	∅0.27" x 1.9"					∅0.5" x 2.9"		∅0.5" x 3.1"		∅0.5" x 2.9"	

## Measurement condenser microphone

The condenser microphone can be used for measurements of sound pressure levels with high resolution over wide frequency ranges. A variety of microphone diaphragm diameters 1, 1/2, 1/4, 1/6, 1/8 inch and corresponding frequency characteristics support various applications.

Specifications												
	Model	7012	7013	7016	7017	7116	7118	7020	7022	7023	7047A	7146NL
Nominal Diameter	1/2 inch		1/4 inch			1/6 inch	1/8 inch	1 inch			1/2 inch	
Release Voltage	-36dB (1.58mV/Pa)	-38dB (12.5mV/Pa)	-49dB (3.5mV/Pa)	-58dB (1.3mV/Pa)	-60dB (1.0mV/Pa)	-72dB (0.25mV/Pa)	-20dB (100.0mV/Pa)	-26dB (50.0mV/Pa)	-28dB (39.8mV/Pa)		-26dB (50.0mV/Pa)	
Polarization voltage	200V										0V	
Frequency Characteristics	10Hz to 40kHz	10Hz to 20kHz	20Hz to 100kHz	20Hz to 20kHz	20Hz to 10kHz	20Hz to 20kHz	20Hz to 10kHz	20Hz to 10kHz	20Hz to 40kHz		20Hz to 20kHz	
Maximum sound pressure level	160dB		164dB			170dB	140dB	146dB		160dB	134dB	
Self-noise level	19dB	21dB	34dB	46dB	45dB	65dB	2dB	11dB	13dB	20dB	15dB	
Temperature coefficient	<0.007dB/°C											
Pre-amplifier Type	Type 4212			Type 4116				Type 4022		Type 4212	Type 4011	
Dimensions	∅0.5" x 0.5"		∅0.3" x 0.4"			∅0.2" x 0.4"	∅0.1" x 0.2"	∅0.9" x 1.1"	∅0.9" x 0.7"		∅0.5" x 0.6"	



# Vibration Meter Model 4200

## Compact, Easy-to-Use Vibration Meter

The new Kanomax vibration meter is designed to be compact, lightweight and easy to use. The magnetic accelerometer attaches easily to machinery for increased accuracy and precise operation. It's the perfect tool to diagnosis problematic vibrations with your industrial machinery or manufactured products.

### Features:

- Compact size maximizes technician mobility
- Magnetic accelerometer increases measuring accuracy and ease-of-use
- Includes meter, accelerometer with cable and magnet, contact pin, 2 x AAA batteries, carrying case, and Calibration Certificate



Specifications		
<b>Measurement Range</b>		
Acceleration		0.02 to 200 m/s <sup>2</sup> RMS
Velocity		0.02 to 200mm/s RMS
Displacement		2 to 2000 μm EQp-p
<b>Frequency Range</b>		
Acceleration		3Hz to 10kHz
Velocity		10Hz to 1kHz (Compliant with JIS B0907-1989)
Displacement		10 to 400Hz
<b>Readings</b>		
		RMS, Peak, EQ Peak, EQ Peak-to-Peak
<b>Output</b>		
AC Output		1Vrms (Full Scale)
Headphone Output		Portable Headphones w/Volume function
<b>Interface</b>		
		RS232C
<b>Operating Environment</b>		
Temperature		-10 to 50°C
Humidity		30% to 90% (no condensation)
<b>Power Supply</b>		
		2 x AAA batteries or AC adapter
<b>Dimensions &amp; Weight</b>		
		5.7"(H)x1.9"(W)x0.9"(D) Approx. 4.6 oz.

### Accessories

- AC-1046:** AC adapter
- Pickup:** AC7812B
- ACPV-0148:** Spare magnet
- ACPV-5050** Strong Magnet
- ACNA-0134:** Auscultation Rod
- ACSS-22M:** Stud
- ACBC-0071:** BNC-Pin Cable
- ACBC-0116-3:** Extension Cable 3m\*
- ACNA-0116:** Data processing software
- ACBC-0026:** Communication Cable (RS232)

\*Additional cable lengths available

# Vibration Monitoring System

Model ACCM-393 is a system to monitor vibration of machinery and other applications. It can quickly detect abnormal vibration condition and provide alarm signal. CM-393 is ideal for continuous vibration monitoring at power plants or production facilities. Either of 2 measurement modes, acceleration or displacement, can be easily selected on the front panel.

Includes storage case, 1 x acceleration pickup with built-in amplifier (Model 7828), pickup cable, and pickup cover.

Specifications		
<b>Model</b>		<b>ACCM-393</b>
<b>Input Impedance</b>		Approx. 100kΩ
<b>Measurement Sensitivity</b>		20mV/m/s <sup>2</sup> (200mV/G)
<b>Measurement Range</b>	Acceleration	1 to 100mm/s <sup>2</sup> (0.1 to 10G)
	Displacement	1 to 1000μp-p
<b>Frequency Response</b>	Acceleration	5Hz to 1kHz
	Displacement	10Hz to 200Hz
<b>Accuracy</b>		Within +/- 5% of full scale
<b>Filter</b>	High-pass	Cut-off Frequency 5Hz to 12dB/oct
	Low-pass	Cut-off Frequency 200Hz to 12dB/oct
		Cut-off Frequency 1kHz to 12dB/oct
<b>Output</b>	Signal for level recorder	4 to 20mA/full-scale Terminal block on the back panel (M4)
	Waveform signal	0 to 2 Vp-p/full-scale BNC connector on the front panel Terminal block on the back panel (M4)
<b>Power Supply</b>		AC 100V +/- 10%, 60Hz
<b>Dimensions</b>		7.9"(H) x 7.5"(W) x 18.5"(D)



\*Variety of acceleration pickups are available.

■ Applications



Monitoring worker exposure to airborne contaminants



Indoor Air Quality Assessments

# *Dust Monitors*





### Piezobalance Dust Monitor Model 3521 / 3522

- Measures PM 10, Respirable, or PM 2.5 particle matter
- Real-time measurements of dust concentration
- Data logging up to 500 measurements
- Simple cleaning mechanism for easy maintenance
- Complete with data processing software, RS232C cable, cleaning kit, Ni-MH battery pack, AC adapter, carrying case, and calibration certificate



### Digital Dust Monitor Model 3443

- Measures PM 10 particle matters
- Compact and Lightweight unit
- Analog output controls other devices
- Data logging up to 100,000 measurements
- PC interface with USB and software for downloading data to your PC
- Complete with rubber protector, shoulder strap, data processing software, USB cable, AC adapter, 2 pcs. LCD protective sheet, rubber cap, 2 pcs. filter, and calibration certificate

#### Specifications

	<b>3521 / 3522</b>	<b>3443</b>
<b>Model</b>	<b>3521 / 3522</b>	<b>3443</b>
<b>Measuring Method</b>	Piezobalance	Light Scattering
<b>Particle Size Range</b>	0.1 to 10 $\mu$ m (Model 3521) 0.1 to 2.5 $\mu$ m (Model 3522)	0.1 to 10 $\mu$ m
<b>Measuring Range</b>	0.01 to 10.00 mg/m <sup>3</sup>	0.001 to 10.000 mg/m <sup>3</sup>
<b>Flow Rate</b>	1.0 L/min	1.0 L/min
<b>Datalogging</b>	500 measurements	100,000 measurements
<b>Interface</b>	RS232C	USB
<b>Analog Output</b>	n/a	0 to 1 V / Pulse / Alarm
<b>Power Supply</b>	Ni-MH Battery or AC 100 - 240 V	AA Batteries or AC 100 - 240 V
<b>Dimensions</b>	W2.6" x H7.1" x D5.9"	W6.7" x H2.7" x D4.3"
<b>Weight</b>	3.9 lbs (1.75 kg)	2.9 lbs (1.3 kg)

# Piezobalance Dust Monitor Model 3521/3522

## Optimal Tool for Monitoring Oil Mist

### Features:

- Measures PM 10, Respirable, or PM 2.5 particle matter, such as dust, oil mist, fume, and soot
- Real-time measurements of dust concentration
- Data logging up to 500 measurements and data may be reviewed on screen or printed
- PC interface with RS232C and software for downloading data to your PC
- Easy operation and requires no special training
- Simple cleaning mechanism for easy maintenance
- Includes data processing software, RS232C cable, cleaning kit, Ni-MH battery pack, AC adapter, carrying case, and calibration certificate

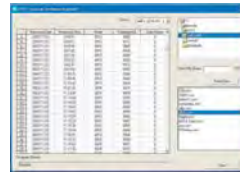

Software Included

Specifications		
Model	3521	3522
Measuring Method	Piezobalance	
Particle Size Range	0.1 to 10 $\mu\text{m}$	0.1 to 2.5 $\mu\text{m}$
Measuring Range	0.01 to 10.00 $\text{mg}/\text{m}^3$	
Flow Rate	1.0 L/min	
Datalogging	500 measurements	
Interface	RS232C	
Power Supply	Ni-MH Battery or AC 100 - 240 V	
Dimensions	W2.6" x H7.1" x D5.9"	
Weight	3.9 lbs (1.75 kg)	

### Accessories

- 3521-01:** Rechargeable Battery Pack
- 3521-02:** Carrying Case
- 3521-03:** 10  $\mu\text{m}$  Impactor Nozzle (for 3521)
- 3521-04:** 4  $\mu\text{m}$  Impactor Nozzle (for 3521)
- 3521-05:** AC Adapter
- 3521-06:** Cleaning Sponges (3 pieces)
- 3521-07:** Cleaning Fluid
- 3521-08:** Communication Cable to PC
- 3521-20:** Printer Cable
- DPU-S245:** Portable Thermal Printer
- TP-202L:** Rolled Printer Paper (10 rolls)

## Dust Measuring Methods

### ■ Piezobalance Method

An air sample enters the system, it travels through the impactor, which captures and removes larger particulates away from the sample. Smaller particulates become electrically charged and deposited on the piezo-crystal. The total mass of the deposited particulates affects the piezo-crystal's frequency. Since the change in frequency is proportional to the mass of the particulates, the actual weight of the particulates is obtained.

Since some particle matters such as oil mist absorb lasers, the Piezobalance dust monitor would be ideal (the light scattering method would not give correct measurements).

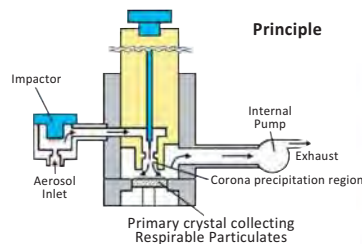

#### Applications:

- Monitoring milling operation
- Monitoring honing
- Monitoring boring operation



Monitoring Milling Operation

### ■ Light Scattering Method

When a laser hits particle matter, light scattering occurs. A dust monitor collects the amount of scattering light and calculates the mass concentration in proportion to the scattering light. Mass concentration is based on the density of particle matter, thus gravimetric sampling is required if the density is unknown.

Applications for light scattering dust monitor include Indoor air quality investigations, Point source monitoring, and Personal exposure monitoring.



Monitoring Welding Operation

# Digital Dust Monitor Model 3443

## Features:

- Measures PM 10 particle matters, such as dust, fumes, and smoke
- Real-time and long term measurements of dust concentration
- Compact and Lightweight unit
- PC interface with USB and software for downloading data to your PC
- Analog output controls other devices
- Data logging up to 100,000 measurements and displays MIN / MAX / AVG and Timing graph for review
- Complete with rubber protector, shoulder strap, data processing software, USB cable, AC adapter, 2 pcs. LCD protective sheet, rubber cap, 2 pcs. filter, and calibration certificate

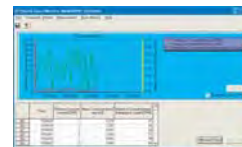

Software Included



With Rubber Protector

Specifications	
<b>Model</b>	<b>3443</b>
<b>Measuring Method</b>	Light Scattering
<b>Particle Size Range</b>	0.1 to 10 $\mu$ m
<b>Measuring Range</b>	0.001 to 10,000 mg/m <sup>3</sup>
<b>Flow Rate</b>	1.0 L/min
<b>Datalogging</b>	100,000 measurements
<b>Interface</b>	USB
<b>Analog Output</b>	0 to 1 V / Pulse / Alarm
<b>Power Supply</b>	AA Batteries or AC 100 - 240 V
<b>Dimensions</b>	W6.7" x H2.7" x D4.3"
<b>Weight</b>	2.9 lbs (1.3 kg)

## Accessories

- 3442-01:** Analog Output Cable
- 3442-02:** Rubber Protector
- 3442-04:** LCD Protective Sheet
- 3442-05:** Carrying Case
- 3431-02:** Rubber Cap
- 3431-03:** Filter (10 pc)
- 6113-02:** AC Adapter
- CX-440:** Tripod

# CEGRIT Automatic Flyash Sampler

## Isokinetic Sampling for Particle Emission Testing

With no moving parts, each CEGRIT sampler collects a sample from one point in the boiler duct. Operating on duct vacuum to drive its atmospheric-air ejector, the CEGRIT maintains near-isokinetic sampling to keep collecting unbiased sample as boiler load and duct vacuum vary.

## Features:

- Operates continuously with no moving parts
- High efficiency sampling rate for fine pulverized dust
- Industrial construction
- Cyclone removes to facilitate periodic cleaning
- Two manometer tap points to monitor draft pressure

## Applications:

- All combustion or other processes where airborne particle emission occurs
- Smoke and particle emissions or grit burdens from boiler stacks
- Carbon determination in Fly ash
- Incinerator emission compliance

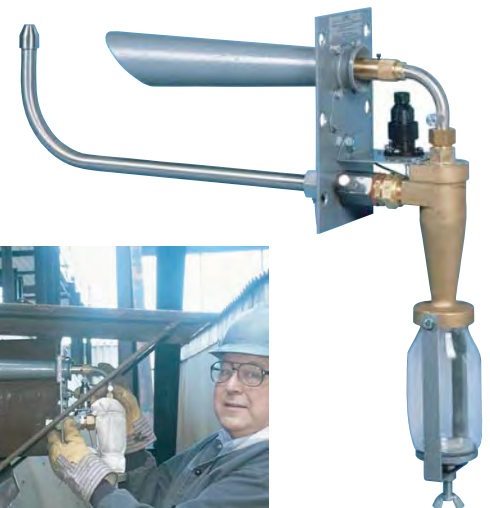

## Accessories

- C8406:** Probe (2 m)
- C8408:** Probe (3 m)
- C8407:** Probe Extension (10 ft)
- C3101:** Inlet Nozzle 1/2" (12.7 mm)
- C3102:** Inlet Nozzle, 5/8" (15.9 mm)
- C3103:** Inlet Nozzle, 3/4" (19.0 mm)
- C3104:** Inlet Nozzle, 3/8" (9.5 mm)
- C5019:** Heater Jacket, 100W, 240 Volt
- C5020:** Heater Jacket, 100W, 110 Volt

## ■ Applications



Cleanroom Certification



Indoor Air Quality Investigation



Filter Testing

# *Particle Counters*





### Handheld Particle Counter Model 3887

Simple and easy-to-use, affordable handheld particle counter

- Simultaneously measures and displays 3 particle sizes
- Built-in flow sensor ensures high accuracy measurement
- Store up to 10,000 measurements
- PC interface with RS232C and software for real-time measurements and downloading data to your PC
- Complete with Isokinetic probe, zero filter, meter stand, data processing software, RS232C cable, 4 pcs. AA batteries, battery charger, AC adapter, and calibration certificate



### Handheld Particle Counter Model 3886 Geo- $\alpha$

Lightweight handheld particle counter with environmental sensors

- Simultaneous measurements of 5 particle sizes
- Air velocity, temperature, and humidity measurements with optional probes
- Data logging up to 500 measurements
- PC interface with RS232C and optional software for real-time monitoring with timing graph
- Includes zero filter, metal handle, 4 pcs. AA batteries, battery charger, AC adapter, and calibration certificate



### Portable Particle Counter Model 3910

Small footprint, lightweight portable particle counter with 50 liter per minute flow rate

- Simultaneous measurements of 6 particle sizes
- 50.0 L/min flow rate
- Small footprint, Stainless enclosure
- Large touch screen LCD displays all measurements simultaneously
- Store up to 10,000 measurements
- PC software allows Remote control, Real-time measuring, and Registering map
- Complete with Quick-start guide, AC adapter, zero filter, Isokinetic probe with 79 inch (2 m) tubing, inlet nozzle, data processing software, memory card, 2 rolls of clean printer paper, Li-ion battery, and calibration certificate

## Specifications

Model	3887	3886	3910
Particle Sizes	0.3 / 0.5 / 5.0 $\mu\text{m}$	0.3 / 0.5 / 1.0 / 3.0 / 5.0 $\mu\text{m}$	0.3 / 0.5 / 1.0 / 3.0 / 5.0 / 10.0 $\mu\text{m}$
Flow Rate	0.1 cfm (2.83 L/min)	0.1 cfm (2.83 L/min)	50.0 L/min
Light Source	Laser Diode	Laser Diode	Laser Diode
Counting Efficiency	50 $\pm$ 20% @ 0.3 $\mu\text{m}$	50 $\pm$ 20% @ 0.3 $\mu\text{m}$	50 $\pm$ 20% @ 0.3 $\mu\text{m}$
Coincidence Loss	Less than 5% at 2,000,000 particles/ft <sup>3</sup>	Less than 5% at 2,000,000 particles/ft <sup>3</sup>	Less than 10% at 500,000 particles/ft <sup>3</sup>
Zero Count Level	Less than 1 count per 5 minutes	Less than 1 count per 5 minutes	Less than 1 count per 5 minutes
Datalogging	10,000 measurements	500 measurements	10,000 measurements
Interface	RS232C or USB	RS232C or USB	Ethernet, USB, Memory card slot (MMC)
Optional Sensor	n/a	Air Velocity / Temperature, Humidity	Air Velocity, Temperature and Humidity
Enclosure	Molded Plastic	Molded Plastic	Stainless Steel
Power supply	4 x AA Batteries or AC 100 - 240 V	4 x AA Batteries or AC 100 - 240 V	Li-ion Battery or AC 100 - 240 V
Dimensions	W4.4" x H7.8" x D2.8"	W4.5" x H8.3" x D2.8"	W7.9" x H8.1" x D7.9"
Weight	1.5 lbs (680 g)	2.2 lbs (980 g)	14.2 lbs (6.44 kg)

## Handheld Particle Counter Model 3887

### Features:

- Simultaneously measures and displays 3 particle sizes
- Built-in flow sensor ensures high accuracy measurement
- Store up to 10,000 measurements
- PC interface with RS232C and software for real-time measurements and downloading data to your PC
- Complete with Isokinetic probe, zero filter, meter stand, data processing software, RS232C cable, USB to serial adapter, 4 pc. AA batteries, battery charger, AC adapter, Carrying case, and calibration certificate



Software Included

Specifications	
<b>Model</b>	<b>3887</b>
<b>Particle Sizes</b>	0.3 / 0.5 / 5.0 $\mu\text{m}$
<b>Flow Rate</b>	0.1 cfm (2.83 L/min)
<b>Light Source</b>	Laser Diode
<b>Counting Efficiency</b>	50% @ 0.3 $\mu\text{m}$
<b>Coincidence Loss</b>	Less than 5% at 2,000,000 particles/ft <sup>3</sup>
<b>Zero Count Level</b>	<1 count per 5 minutes
<b>Datalogging</b>	10,000 measurements
<b>Interface</b>	RS232C or USB
<b>Enclosure</b>	Molded Plastic
<b>Power Supply</b>	4 x AA Batteries or AC 100 - 240 V
<b>Dimensions</b>	W4.4" x H7.8" x D2.8"
<b>Weight</b>	1.5 lbs (680 g)

### Accessories

- 3887-02:** Carrying Case  
**3887-07:** Printer Cable  
**DPU-S245:** Portable Thermal Printer  
**TP-202L:** Rolled Printer Paper (10 rolls)  
**CX-440:** Tripod  
**301APK:** Intl. Plug Adapter Kit



Carrying Case

## Handheld Particle Counter Model 3886 Geo-Q<sup>®</sup>

### Features:

- Simultaneous measurements of 5 particle sizes
- Air velocity, temperature, and humidity measurements with optional probes
- Data logging up to 500 measurements
- PC interface with RS232C and optional software for real-time monitoring with timing graph
- Compact and lightweight, easy handling
- Includes AC adapter, zero filter, metal handle, 4 pc. AA batteries, battery charger and calibration certificate

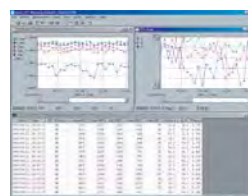

Software for Monitoring and Remote Control

Specifications	
<b>Model</b>	<b>3886</b>
<b>Particle Sizes</b>	0.3 / 0.5 / 1.0 / 3.0 / 5.0 $\mu\text{m}$
<b>Flow Rate</b>	0.1 cfm (2.83 L/min)
<b>Light Source</b>	Laser Diode
<b>Counting Efficiency</b>	50% @ 0.3 $\mu\text{m}$
<b>Coincidence Loss</b>	Less than 5% at 2,000,000 particles/ft <sup>3</sup>
<b>Zero Count Level</b>	<1 count per 5 minutes
<b>Datalogging</b>	500 measurements
<b>Interface</b>	RS232C or USB
<b>Optional Sensor</b>	Air Velocity / Temperature, Humidity *See page 33 for specs
<b>Enclosure</b>	Molded Plastic
<b>Power Supply</b>	4 x AA Batteries or AC 100 - 240 V
<b>Dimensions</b>	W4.5" x H8.3" x D2.8"
<b>Weight</b>	2.2 lbs (980 g)

### Accessories

- 0842:** Temperature and RH Probe  
**0843:** Air Velocity Probe  
**0843-01:** Extension Rod for 0843  
**3886-02:** Carrying Case  
**3886-04:** Isokinetic Probe  
**S388-61:** Data Processing Software for Windows  
**3886-07:** Printer Cable  
**3886-08:** Communication Cable to PC  
**DPU-S245:** Portable Thermal Printer  
**TP-202L:** Rolled Printer Paper (10 rolls)  
**CX-440:** Tripod

# Portable Particle Counter Model 3910

Smallest and lightest 50LPM portable particle counter

## Features:

- Simultaneous measurements of 6 particle sizes
- Small footprint, Stainless enclosure
- 50 L/min (1.77 cfm) flow rate
- Complies with all requirements of ISO 21501-4
- Large touch screen LCD displays all measurements simultaneously
- Store up to 10,000 measurements
- 21 CFR Part 11 compliance
- Complete with Quick-start guide, AC adapter, zero filter, Isokinetic probe with 79 inch (2 m) tubing, inlet nozzle, data processing software, memory card, 2 rolls of clean printer paper, 1 x Li-ion battery, and calibration certificate



Specifications	
Model	<b>3910</b>
Particle Sizes	0.3 / 0.5 / 1.0 / 3.0 / 5.0 / 10.0 $\mu\text{m}$
Flow Rate	1.77 cfm (50 L/min)
Light Source	Laser Diode
Counting Efficiency	50% @ 0.3 $\mu\text{m}$ per ISO21501-4
Coincidence Loss	Less than 10% at 500,000 particles/ft <sup>3</sup>
Zero Count Level	<1 count per 5 minutes
Datalogging	Up to 10,000 sample records
Interface	Ethernet, USB, Memory card slot (MMC)
Optional Sensor	Air Velocity, Temperature, Humidity / Differential Pressure
Enclosure	Stainless Steel
Power Supply	Li-ion Battery or AC 100 - 240 V
Battery	Removable/rechargeable Li-ion batteries (2 battery slots)
Dimensions	7.9 x 8.1 x 7.9 inches (200 x 205 x 200 mm) without handle
Weight	14.2 lbs (6.44 kg)



Model 3910

Conventional Unit

Small, Lightweight Unit

## ■ Optional environmental sensor



Optional Climomaster™ Environmental Sensor measures airflow, temperature and humidity.

Probe Specifications	
Model	<b>6531-2G-P</b>
Probe Type	Uni-Directional
Air Velocity	2 to 6000 fpm
Temperature	-4 to 158°F
Relative Humidity	2.0 to 98.0 %RH



Climomaster™ probe for environmental measurements

## Accessories

<b>6531-2G-P:</b>	Air velocity, Temp, RH probe with 2 m cable	<b>3910-08:</b>	Zero filter
<b>3910-01:</b>	Carry case	<b>3910-09:</b>	Printer paper
<b>3910-02:</b>	Battery charger	<b>CRVAL:</b>	Validation, IQ/OQ Document
<b>3910-03:</b>	Spare Li-ion battery		
<b>3910-04:</b>	Alarm-output cable		
<b>3910-05:</b>	Pressure-sensor (w/ connection cable)		

# Handheld Condensation Particle Counter Model 3800

## Optimal Screening Tool for Nano Size Particles

### Features:

- 0.015 micron (15nm) minimum sensitivity
- Handheld and Lightweight Aerosol Research Instrument
- Store up to 10,000 measurements
- PC interface with USB and software for real-time measurements and display time fluctuation graph
- Complete with zero filter, data processing software, USB cable, alcohol bottle, 6 pc. AA batteries, carrying case, and calibration certificate



Software Included

### Measuring Principle

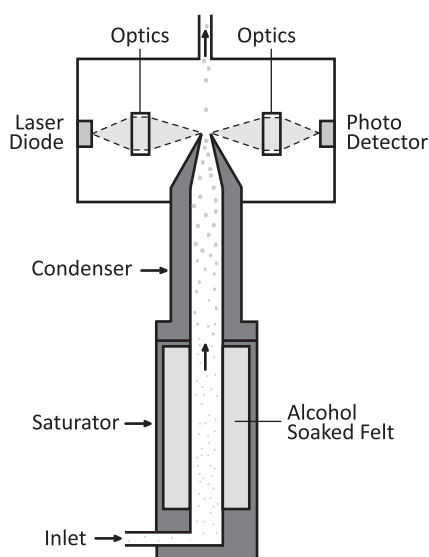

Specifications	
Model	<b>3800</b>
Measuring Object	Airborne Particle Matter
Particle Sizes	0.015 to 1.0 $\mu\text{m}$
Flow Rate	0.7 L/min
Light Source	Laser Diode
Counting Efficiency	100% @ 0.050 $\mu\text{m}$ More than 50% @ 0.015 $\mu\text{m}$
Coincidence Loss	Less than 5% at 100,000 particles/cm <sup>3</sup>
Zero Count Level	<1 count per 5 minutes
Alcohol Supply	Isopropyl Alcohol
Datalogging	10,000 measurements
Interface	USB
Power Supply	6 x AA Batteries or AC 100 - 240 V
Dimensions	W4.7" x H11.0" x D5.1"
Weight	3.3 lbs (1.5 kg)

### Applications



Checking Worker Exposure to Airborne Contaminants



Leakage Testing



Engine Exhaust Testing

### Accessories

- 3800-01: AC Adapter
- 3800-02: Zero Filter
- 3800-03: Alcohol Bottle
- 3800-04: Storage Cap
- 3800-05: Alcohol Cartridge
- 3800-06: Spare Felt and Wire Mesh

- 3800-07: Communication Cable to PC
- 3800-08: Carrying Case
- 3800-10: Sampling Probe with 1m Tubing
- 3800-11: Printer Cable
- DPU-S245: Portable Thermal Printer
- TP-202L: Rolled Printer Paper (10 rolls)



# Particle Size Chart

100 10 1 0.3 0.1 0.01 0.001 particles in micron sizes

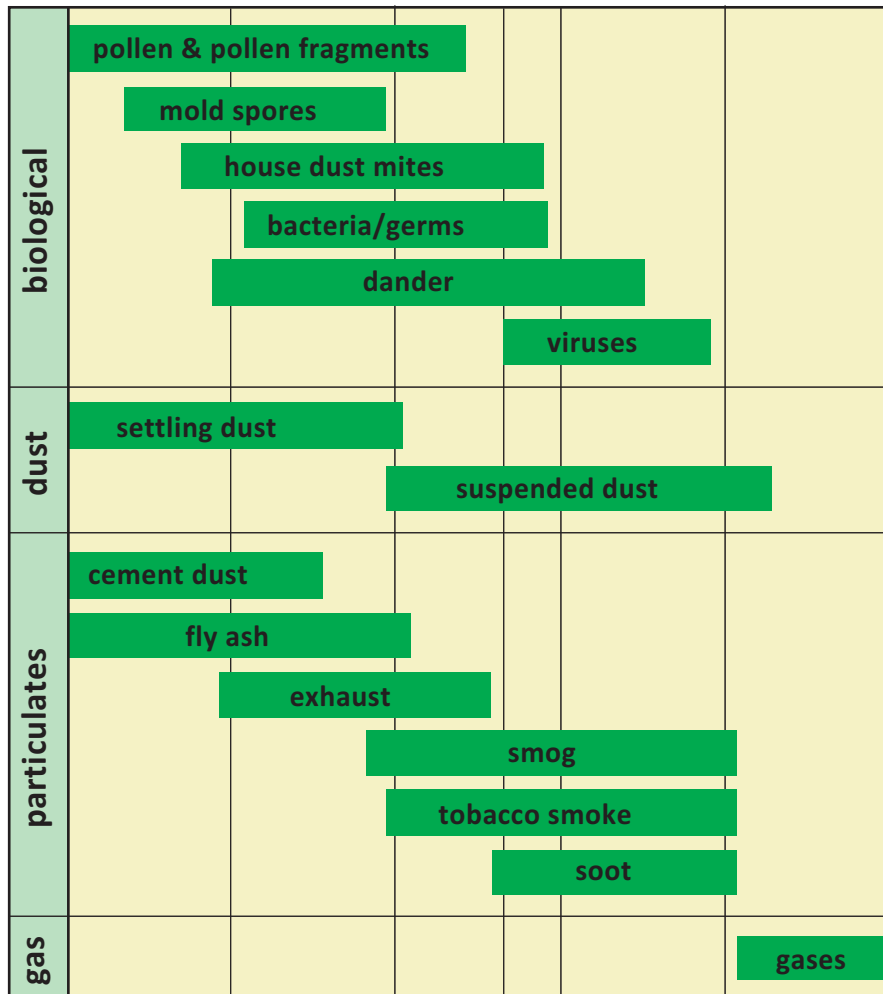

## Kanomax Product Operation Ranges

## Applications

<ul style="list-style-type: none"> <li>3522 Dust Monitor</li> <li>3521 Dust Monitor</li> <li>3443 Dust Monitor</li> </ul>	<ul style="list-style-type: none"> <li>Industrial Hygiene Survey</li> <li>Personal Exposure Monitoring</li> <li>Occupational Safety Control</li> <li>Manufacturing Process Control</li> </ul>
<ul style="list-style-type: none"> <li>3887 Particle Counter</li> <li>3886 Particle Counter</li> <li>3910 Particle Counter</li> </ul>	<ul style="list-style-type: none"> <li>Indoor Air Quality Investigation</li> <li>Mold Remediation Assessment</li> <li>Cleanroom Certification</li> <li>Filter Testing</li> </ul>
<ul style="list-style-type: none"> <li>3800 Condensation Particle Counter</li> </ul>	<ul style="list-style-type: none"> <li>Diesel Exhaust Research</li> <li>Combustion Particle Research</li> <li>Occupational Health Research</li> <li>Nanoparticle Survey</li> </ul>

100 10 1 0.3 0.1 0.01 0.001 particles in micron sizes

## Guide to Selecting a Particle Counter for Cleanroom Certification

This guide will use the ISO 14644: 1999 standards as a guide to help customers select an appropriate particle counter for use in certifying or spot-checking their cleanroom. This is a basic guide designed to help businesses or customers who need guidance in choosing the correct particle counter for their application.

At the bottom of the page is a copy of the ISO standard indicating the classes of cleanrooms and acceptable particle levels for each.

There are two main factors that influence the choice of a particle counter:

The first is the particle size(s) that are to be monitored. This is partially determined by the ISO class of the particular cleanroom, but also depends on the customer's needs. Typically a customer will choose one or two particles for the certification test (if you need help choosing which particle sizes to monitor please refer to the ISO standard). When purchasing your particle counter you will need to check the specifications to ensure the instrument can measure particles of the appropriate size(s).



Kanomax particle counters have the following particle size ranges:

Particle Counter Model #	Particle Size Range
3887 Handheld	0.3 / 0.5 / 5.0 $\mu\text{m}$
3886 Handheld	0.3 / 0.5 / 1.0 / 3.0 / 5.0 $\mu\text{m}$
3900 Portable	0.3 / 0.5 / 1.0 / 3.0 / 5.0 / 10.0 $\mu\text{m}$
3910 Portable	0.3 / 0.5 / 1.0 / 3.0 / 5.0 / 10.0 $\mu\text{m}$



Portable Particle Counter Model 3910

ISO Cleanroom Classification Table

	ISO classification	Highest levels of particle concentrations (particles/m <sup>3</sup> ) equal to or greater than the parameters listed as follows.					
		0.1 $\mu\text{m}$	0.2 $\mu\text{m}$	0.3 $\mu\text{m}$	0.5 $\mu\text{m}$	1.0 $\mu\text{m}$	5.0 $\mu\text{m}$
Certify every 6 months	Iso Class 1	10	2	-	-	-	-
	Iso Class 2	100	24	10	4	-	-
	Iso Class 3	1,000	237	102	35	8	-
	Iso Class 4	10,000	2,370	1,020	352	83	-
	Iso Class 5	100,000	23,700	10,200	3,520	832	29
Certify every 12 months	Iso Class 6	1,000,000	237,000	102,000	35,200	8,320	293
	Iso Class 7	-	-	-	352,000	83,200	2,930
	Iso Class 8	-	-	-	3,520,000	832,000	29,300
	Iso Class 9	-	-	-	35,200,000	8,320,000	293,000

Make sure you choose a particle counter that can measure all the particle sizes that need to be monitored.

The second factor that you'll want to consider is the flow rate capability of the particle counter. In order to do that we need to consider one of the formulas from the ISO standard:

$$\text{Formula: } V_s = (20/C_{nm}) \times 1000$$

$V_s$  = the minimum single sample volume per location, expressed in litres

$C_{nm}$  = is the class limit (number of particles per cubic meter) for the largest considered particle size specified for the relevant class.

20 = the defined number of particles that could be counted the particle concentration were at the class limit.

This formula will calculate how many liters of air need to be sampled at each location in the cleanroom. Here's an example to clarify:

Let's say we're certifying an ISO class 6 cleanroom. The largest considered particle size for this class is 5.0  $\mu\text{m}$  of which the cleanroom must have less than 293 particles per  $\text{m}^3$ . So if we take our formula and plug that # in it will look like this:

$$V_s = (20/293) \times 1000$$

If we calculate the formula we come up with  $V_s = 68.3$ . So in order to certify this cleanroom we need to sample 68.3 litres of air at each measuring point. That means that if we choose a small handheld particle counter with a flow rate of 2 litres per minute we will have to sample the air for 34.2 minutes at each measuring point. In this case it may be more economical to use a particle counter with a faster flow rate to minimize the time spent certifying the cleanroom.

**Kanomax particle counters have the following flow rates:**

Particle Counter Model #	Flow Rate
3887 Handheld	2.83 L/min
3886 Handheld	2.83 L/min
3900 Portable	28.3 L/min
3910 Portable	50.0 L/min

In summary, handheld counters tend to be the ideal economical solution for spot-checking and certifications where high volume measurements aren't required. Larger portable units with a higher flow rate are better suited for applications where a significant volume of air needs to be sampled at each point.

Beyond these basic functions you may also want to consider additional features that come with your particle counter. For example, our models 3887 and 3910 come pre-programmed with the ISO formulas. The 3886 and 3910 have optional probes that can measure airflow, temperature and relative humidity. Features like this can be real time savers if they are relevant to your specific application.

Kanomax also offers several other instruments that can be used to perform other cleanroom tests in accordance with ISO standards. ISO 14644-3:2005(E) section B4, which details checking the airflow in uni-directional and non-unidirectional air flow environments.



# Cleanroom Monitoring System



Kanomax Cleanroom Monitoring System (CRMS) provides an automated means to monitor and gather airborne particle counts and other parameter levels in controlled environments. CRMS allows users to perform a variety of functions from a PC, including changing alarm settings and viewing particle count concentrations.



## Features:

- Compact stainless enclosure with sensors
- Multi-parameter measurements: Particle count, Air velocity, Temperature, Humidity, and Differential pressure
- Multi-function, user-friendly monitoring software
- 1 PC system controls up to 128 sensors
- Alarm outputs: warning light, on-screen, or pager notification
- No system down-time: each sensor is replaceable for repair and recalibration

## Particle Sensors

### Features:



- Light scattering particle sensor
- Durable stainless enclosure is easy to sanitize during whole facility cleaning

### Specifications

Model	3714	3715
Measuring Object	Airborne Particle Matter	
Particle Sizes	0.3 / 0.5 $\mu\text{m}$	0.5 / 5.0 $\mu\text{m}$
Flow Rate	0.1 cfm (2.83 L/min) *External vacuum source is required	
Light Source	Laser Diode	
Counting Efficiency	50% @ 0.3 $\mu\text{m}$	50% @ 0.5 $\mu\text{m}$
Coincidence Loss	Less than 5% at 1,000,000 particles/ft <sup>3</sup>	
Zero Count Level	<1 count per 5 minutes	
Interface	RS485	
Enclosure	Stainless Steel	
Power Supply	DC24V (Supplied from the 3770)	
Dimensions	W5.0" x H2.8" x D1.6"	
Weight	1.1 lbs (500 g)	

### Features:



- 0.2  $\mu\text{m}$  sensitivity particle counter
- Digital and analog outputs are available
- Analog output for Multiplexer

### Specifications

Model	3792-01
Measuring Object	Airborne Particle Matter
Particle Sizes	0.2 / 0.3 $\mu\text{m}$
Flow Rate	0.1 cfm (2.83 L/min)
Light Source	Laser Diode
Counting Efficiency	50% @ 0.2 $\mu\text{m}$
Coincidence Loss	Less 5% at 1,000,000 particles/ft <sup>3</sup>
Zero Count Level	<1 count per 5 minutes
Interface	RS485 / 4 to 20 mA for Multiplexer
Power Supply	AC 100 to 240 V
Dimensions	W4.6" x H5.3" x D6.7"
Weight	6.6 lbs (3 kg)

## Air Velocity Sensor

### Features:



- Compact design for measuring air velocity and airflow in cleanroom
- 10 interchangeable probes are available
- Temperature/Humidity sensor and Differential pressure sensor are available

### Specifications

Model	6332 / 6332D
Air Velocity Ranges	20 to 9840 fpm (0.10 to 50.0 m/s) *See page 15 for probe specifications
Analog Output	4 to 20mA or 0 to 5V
Power Supply	DC 12 to 24V or AC 80 to 240V
Dimensions	W3.1" x H5.0" x D1.2"
Weight	0.7 lbs (320 g)

## Interface Box



### Features:

- Converts analog input to digital
- Supplies power to the sensor

### Specifications

<b>Model</b>	<b>3772-02</b>
<b>Input</b>	4 to 20 mA / 0 to 1 V / 1 to 5 V
<b>Output</b>	RS485
<b>Power Supply</b>	DC24V (Supplied from the 3770)
<b>Dimensions</b>	W5.5" x H3.1" x D1.6"
<b>Weight</b>	1.1 lbs (500 g)



with Differential Pressure Sensor

## Distributors



### Features:

- Supplies data communication and power to sensors via RS485
- 1 unit connects up to 8 sensors

### Specifications

<b>Model</b>	<b>3770</b>
<b># of Channel</b>	8
<b>Interface</b>	RS485
<b>Power Supply</b>	AC 85 to 132 V or AC 170 to 267 V
<b>Dimensions</b>	W11.8" x H3.9" x D7.9"
<b>Weight</b>	6.6 lbs (3 kg)

## Cleanroom Monitoring Software

### Features:

- Continuous monitoring and data processing software
- Remote monitoring via LAN
- Multi-function: Map display at a glance, Real-time graph, Maintenance Indication, and Data table



Map

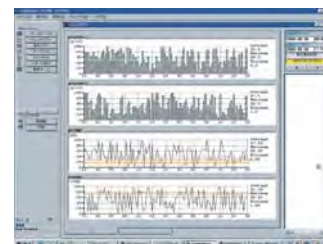

Trend Graph

## System Examples

### Industrial Cleanroom

Semiconductor, HDD, Flat Panel Display, Electronics

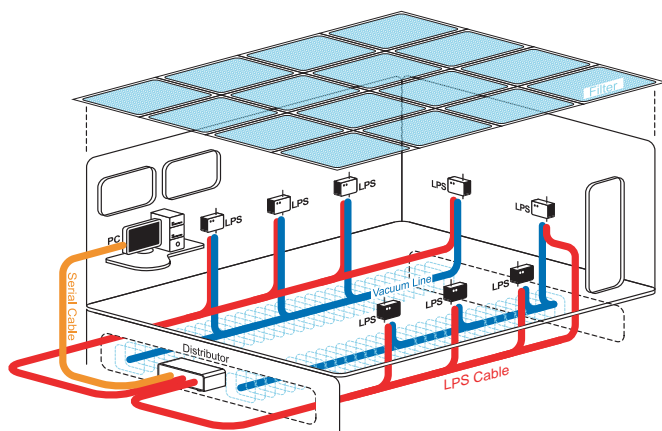

### Bio-medical Cleanroom

Food, Pharmaceutical, Hospital surgical rooms

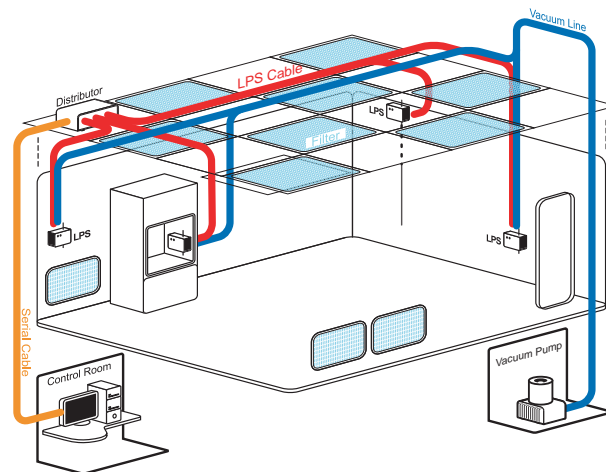

# Aerosol Research Instruments

Our line of aerosol research instruments cover a variety of applications.

## Industrial hygiene



Health effect research

Nano-particle research



Nano Sampler



Aerosol Particle Mass Analyzer

## Air pollution



Ambient air quality research



Ambient Air Quality Monitor



Condensation Particle Counter

## Earth sciences



Environmental research

Climate change research



Black Carbon Monitor



Aerosol Particle Mass Analyzer

## Aerosol Particle Mass Analyzer Model APM-3600

Aerosol Particle Mass Analyzer classifies particles by mass based on the balance between centrifugal force and electrostatic force. Particle size distribution measurement is normally used in order to measure nanosized particle distribution. While DMA (Differential Mobility Analyzer) classifies particles by particle size utilizing electrostatic force, APM classifies particles by mass based on entirely new classification principles. APM classifies aerosol particles of 0.01 ~ 100 femtograms. Particle density distribution can be attained by combining the APM and DMA.

### Applications:

- Mass distribution measurements
- Particle density research
- Monodisperse aerosol generation



Specifications	
Model	APM-3600
Particle Mass Range	0.01 to 100 femtogram Equivalent to approx. 30 nm to 580 nm for particle density of 1 g/cm <sup>3</sup> )
Classification Accuracy	Within +/- 10 % of the center mass
Maximum Rotation Speed	Up to 9500 rpm
Maximum Voltage	Up to 2000V
Rotating Cylinder Dimensions	Inner cylinder diameter: 100 mm / Outer cylinder diameter: 104 mm Gap between cylinders: 2 mm Cylinder length: 250 mm
Sampling Flow Rate	1 L/min
Power Supply	AC 115V
Dimensions	Main Unit: W 21.7" x H 35.4" x D 15.7" Control Unit: W 16.9" x H 13.8" x D 7.1"
Weight	Main Unit: 275 lbs (125 kg) Control Unit: 22 lbs (10 kg)

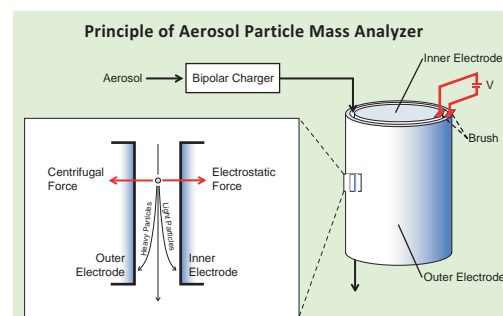

## Aerosol Particle Mass Analyzer Model APM-3601

### Lightweight, Desktop APM

#### Features:

- Lightweight, Desktop Unit
- Measurement software, communication cable, extension board, extension adapter and box, and plastic case are available as options

Specifications	
Model	APM-3601
Particle Mass Range	0.01 to 1000 femtogram Equivalent to approx. 14 nm to 1.3 μm for particle density of 1 g/cm <sup>3</sup> )
Maximum Rotation Speed	1,000 to 14,000 rpm
Maximum Voltage	Up to 2,000 V
Rotating Cylinder Dimensions	Inner Cylinder Diameter: 48 mm Gap between Inner and Outer Cylinders: 1 mm Cylinder Length: 100 mm
Sampling Flow Rate	0.3 to 1.0 L/min (0.3 L/min is recommended)
Power Supply	Single-phase AC100 ~ 240V
Dimensions	Main Unit: W 16.9" x H 5.5" x D 7.9" Control Unit: W 16.9" x H 7.1" x D 13.8"
Weight	Main Unit: 23 lbs (10.5 kg) Control Unit: 15 lbs (7 kg)



Rotating Cylinder Assembly



Control Unit

## ***Black Carbon Monitor Model 3130***

### **Continuous Soot Monitoring System**

The Model 3130 monitors changes in transmittance across an automatically advancing quartz fiber filter tape using an LED at a 565 nm wavelength. To achieve measurements with high sensitivity and a lower detectable light absorption coefficient, the Model 3130 uses a double-convex lens and optical bundle pipes to maintain high light intensity and signal data, obtained at 1000 Hz.

#### **Features:**

- Measures black carbon concentration in the air in real time
- Preprocessing of sample air improves measurement accuracy
- Automatic filter feed enables continuous measurement for extended periods
- Advanced detection sensitivity enables measurement in low concentration areas
- Complete with inlet heater, pump, pump controller, 2.5  $\mu\text{m}$ -cut impactor, Software, and power cable

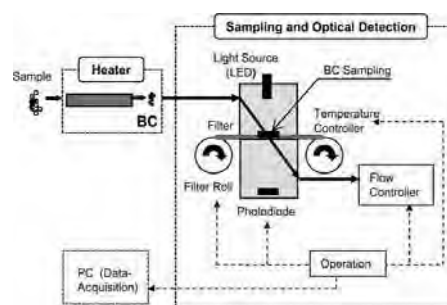

System Diagram

Specifications	
Model	3130
Measurement Method	Light Absorption Method
Light Source	LED Wavelength 565 nm
Lowest Detection	0.05 $\mu\text{g}/\text{m}^3$ @1 min @0.8 L/min
Collection Flow Rate	0.8 L/min
Collection Filter	Fiberglass Filter (Length: 25 m)
PC Interface	USB
Power Supply	100 VAC, 6A
Dimension	W 17" x H 8.7" x D 13.9"
Weight	37.5 lbs (17kg)

## ***Nanosampler Model 3180***

### **Inertial Filter for Aerosol Collection**

Fiber filters utilize several mechanisms for aerosol collection such as inertial, gravitational settling, interception, and diffusion. Each collection efficiency depends on particle size and filtration velocity. Large particles are collected in a filter by inertial impaction at a high filtration velocity while small particles are removed from the air by Brownian diffusion.

The Model 3180 controls its diffusion collection increasing filtration velocity, and collecting particles only by inertia.

#### **Features:**

- Particle classification as small as 0.1  $\mu\text{m}$
- 5 stages of PM10, 2.5, 1.0, 0.5, 0.1 and Backup filter
- Large sample flow rate of 40 L/min
- Includes 1 box of quartz fiber filter (55mm x 100 pc.), and 5 sets of PM0.1 cartridge
- Pump unit (Vacuum pump + Rota meter with valve), PM0.1 cartridge case (1 case for 5 cartridges), Quartz fiber filter case (1 set of 20 cases), PM0.1 absorption materials (10 sets) are available



Specifications	
Model	3180
Classification Method	Inertial Collection
Classification Range	PM 10, PM 2.5, PM 1.0, PM 0.5, PM 0.1 and Backup filter
Absorption Material	Quartz Fiber Filter: PM 10, PM 2.5, PM 1.0, PM 0.5, and Backup filter SUS fiber: PM0.1
Sampling Flow Rate	40 L/min
Dimensions	$\varnothing$ 3.5" x 8.3"
Weight	6.6 lbs (3 kg)



# AQM60 Ambient Air Quality Monitor



## Features:

- Multiple gas sensors (up to six)
- Temperature and humidity sensors
- Particulate monitor (PM2.5 or PM10)
- Wind speed and direction anemometer
- Noise and meteorological sensors
- Rapid real-time data sampling (2-minute)
- Wired or Wireless communication
- Large data storage capacity (>15 years)
- Thermal management system
- Weatherproof and compact enclosures
- Insulated roadside boxes, Metal enclosures, Mounting accessories are available

## Main Unit Specifications

Model	AQM60
Environment Operation Range	Standard: 50 to 77 F (10 C to 25 C) With Heater/Cooler: -4 to 113 F (-20 C to 45 C) 10 to 90 %RH (non condensing)
Communications Options	GSM modem / RF modem / Ethernet LAN
Other Sensor Options	Noise sensors / Particle counters / Meteorological sensors
Power Supply	12VDC / AC power module 100 - 250 VAC
Enclosure	Standard: Fiber reinforced polycarbonate
Dimensions	H 23.6" x W 19.7" x D 9.1" (600 x 500 x 230 mm)
Weight	33 to 55 lb (15 to 25 kg), subject to configuration



## Gas Sensor Specifications

Gas Sensor Modules	Sensor	Range (ppm)	Accuracy	Resolution	Power
Ozone	GSS	0 - 0.150	<+/- 0.005 ppm	0.001 ppm	2.9 W
Nitrogen dioxide	GSS	0 - 0.200	<+/- 15%	0.001 ppm	12.3 W
Carbon monoxide	GSS	0 - 100	<+/- 5 ppm	0.1 ppm	2.5 W
Sulphur dioxide	GSS	0 - 10	<+/- 0.5 ppm	0.01 ppm	2.5 W
Non-methane hydrocarbon	GSS	0 - 25	<+/- 0.5 ppm	0.1 ppm	2.5 W
VOC isobutylene	GSS	0 - 25	<+/- 10%	0.1 ppm	2.5 W
VOC isobutylene	PID	0 - 20	<10%	0.01 ppm	1.5 W
Hydrogen sulphide	GSS	0 - 10	<+/- 0.5 ppm	0.01 ppm	2.5 W
Carbon dioxide	NDIR	0 - 2,000	<40 ppm + 3%	1 ppm	1.0 W

# Fluidized Particle Generator

Kanomax Fluidized Particle Generators generate standard particles continuously for a long time. Applications are pharmaceutical and chemical compound exposure research, and filtration performance testing.



Model 3211



Model 3216

## Features:

- Available for variety of sample particles
- Long time operation
- Stably generated particle concentration
- Easy control on the concentration level

## Specifications

Model	3211	3216
Particle Sizes	Less than 20 $\mu\text{m}$	0.2 to 10 $\mu\text{m}$
Density	100 mg/m <sup>3</sup> to 1 g/m <sup>3</sup>	20 g / m <sup>3</sup>
Flow Rate	30 L/min	
Power Supply	AC100V, 50/60Hz	
Dimensions	W 6.7" x H 17.5" x D17.7"	W 20.1" x H 61.4" x D15.9"

■ Applications



Food analysis



Forensic Science



Medical



Environmental analysis

# *Mass Spectrometry*



**INFITOF**  
Hi-Resolution & Compact TOF-MS



# Time of Flight Mass Spectrometer

High performance and small foot print time of flight mass spectrometer by using the multi-turn technology

## Features:

- High resolution and compact time of flight mass spectrometer
- Impure substances analysis in gases with the detection limit of 10ppb
- Onsite detailed accurate analysis

## Applications:

- Food analysis
- Particle analysis
- Environmental analysis
- Forensic: detection of forged paintings
- Medical: blood test, hair analysis etc



**INFI TOF**  
Hi-Resolution & Compact TOF-MS

## Specifications

<b>Resolution</b>	More than 30,000
<b>Dynamic Range</b>	10bit
<b>Sampling Rate</b>	2GS/s
<b>Weight</b>	79 lbs (36kg)
<b>Dimensions</b>	H9.2" x W17.9" x D25.2" (234 x 456 x 640 mm)



with Gas chromatography (optional)

## ■ Key Technology "Multi-Turn Time of Flight Mass Spectrometry"

There are four orbiting electrodes and two injection/ejection electrodes on a palm-sized optics bench. The ion source gives kinetic-energy for orbiting motion in the infinite loop. Injection and ejection electrodes are synchronized with ion source pulsing triggering. Injection electrode has to be in the on state while ions enter the analyzer, and then has to be turned off before first ion (smallest ion) returns to it. Orbiting electrodes are constant, so orbiting ion can be held until ejection electrode is ON.

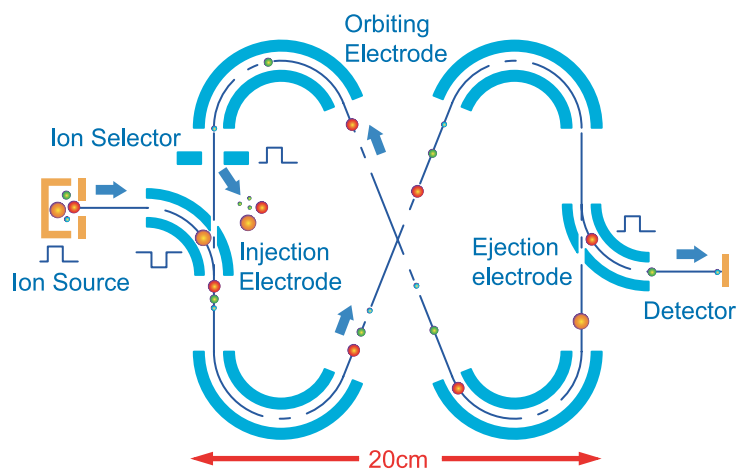



# Automotive Testing Instruments

## Amenity Manikin System

### Cabin Comfort Test Rig

Kanomax Amenity Manikin System is a solution for precise interior cabin comfort evaluation. The system measures parameters; air velocity, temperature, humidity, and radiant heat, which relate to human comfort level. One mannequin equips more than 120 sensors all over its surface and provides sophisticated measurement.

#### Features:

- 4 mannequins measure simultaneously; providing understanding of the entire cabin
- Wireless connection makes operation easy
- Graphical software for both real-time measurement and data retrieval
- Excel compatible data output and ability to save graphic data for review



Amenity Manikin

#### Sensor Allocations by Part

	Air Velocity	Temperature	Humidity	Radiant Heat
Head	4	12	1	3
Upper Torso	12	33	0	5
Lower Body	20	33	1	4
<b>Total</b>	<b>36</b>	<b>78</b>	<b>2</b>	<b>12</b>

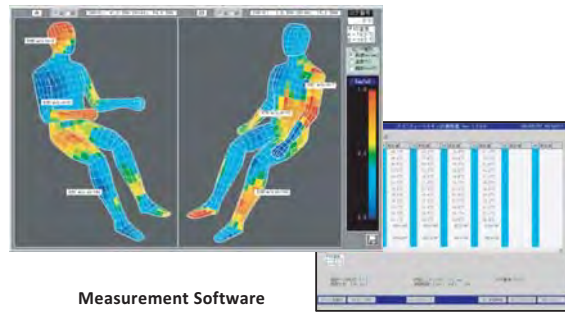

Measurement Software

#### Mannequin Specifications

Height	Approx. 5'6" (170cm)
Weight	90 lbs (40 kg)
Material	Plastic (FRP)

#### Sensor Specifications

<b>Air Velocity Ranges</b>	0.10 to 5.00 m/s
Accuracy	0.05 m/s
<b>Temperature Ranges</b>	30 to 100°C
Accuracy	+/- 3.0°C
<b>Humidity Ranges</b>	3 to 95 %RH
Accuracy	+/- 3 %RH
<b>Radiant Heat Ranges</b>	0 to 1 kw/m <sup>2</sup>
Accuracy	+/- 7 %
Wavelength	0.3 to 40 μm

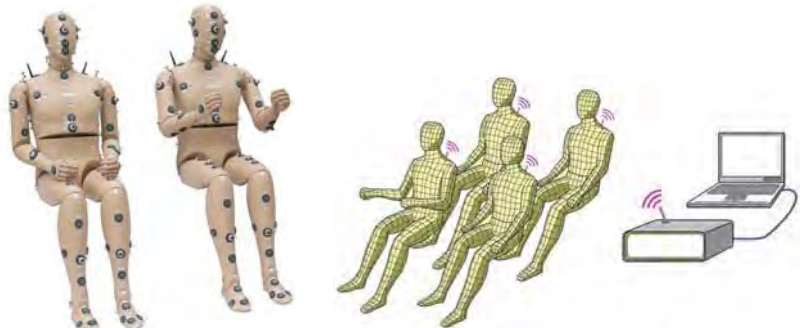



# Vehicle Cabin Leakage Testers

## Cabin Comfort Test Rig

Leakage testing is performed by pressurizing or depressurizing the vehicle cabin. The tester measures the changes in cabin pressure. The control unit consists of a manometer and pressure transducers. The manometer detects the leakage flow, which is calculated by measuring the nozzle pressure relative to static pressure. The tester controls an adjustable fan to maintain static test pressure. Five selectable inlet nozzles provide reasonable leakage flow rate measurements of 2.5 to 800 cfm.

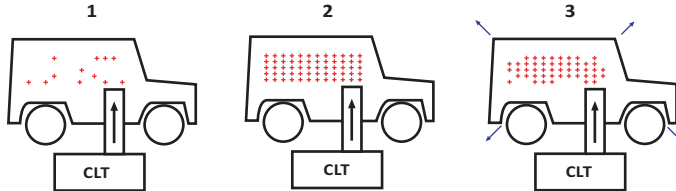

1. The cab is pressurized (either positively or negatively)
2. Pressure will be stable, normally stable conditions are achieved quickly
3. The leakage rate is measured



CLT-APC-NPP



CLT-MPC

### Features:

- Automatic Pressure Control
- Negative Pressure Testing
- Features High Accuracy Manometer
- System includes inlet nozzles, certificate of conformance to ISO 5801: 1997, and pressure measurement calibration certificate

Specifications	CLT-MPC	CLT-MPC-NPP	CLT-APC	CLT-APC-NPP
Model	CLT-MPC	CLT-MPC-NPP	CLT-APC	CLT-APC-NPP
Fan Speed	847 cfm (400 L/sec)			
Pressure Measurement Accuracy	+/- 2 % of reading +/- 1 digit			
Leakage Flow Measurement Accuracy	+/- 3 % of reading +/- 1 digit Providing flow rate is varied by the nozzle * See nozzle specs			
Cabin Pressure Preset Ranges	-		0.2 to 2 in. H <sub>2</sub> O (5 to 499 Pa)	
Automatic Pressure Control	-		○	
Negative Pressure Plenum	-	○	-	○
Small Transport Cart	○		-	
Power Supply	120/240 V, 1 phase			
Duct Size	16.4 ft x ø8 inches (5 m x ø203 mm)			
Dimensions	Small Transport Cart: W 22.5" x H 23.5" x D 54" Large Transport Cart: W 27.5" x H 42" x D 58.5"			

Nozzle Specifications		
Nozzle	Inlet Diameter	Flow Ranges
F	0.590" (15 mm)	2.5 to 10 cfm (1.2 to 4.8 l/s)
G	1.122" (28.5 mm)	8.5 to 36 cfm (4 to 17 l/s)
H	2.204" (56 mm)	32 to 142 cfm (15 to 67 l/s)
D	3.543" (90 mm)	53 to 296 cfm (25 to 140 l/s)
E	6.023" (153 mm)	190 to 847 cfm (90 to 400 l/s)

# Smoke Generator Model 8304

## Smoke Generator for Air Flow Visualization

The Model 8304 is a smoke generator for wind tunnel testing and aerodynamics visualization. It produces vaporizing white smoke of 15 to 80L/min. Compressed air moves smoke to the comb-shaped nozzle and makes streamlines.



Nozzle



### Features:

- Versatile and Portable unit
- High output, non-toxic, water-soluble smoke
- System cart, air compressor, and comb-shaped nozzle are available as options

Specifications	
Model	8304
Smoke Output	15 to 80 L/min
Smoke Particle Size	0.3 to 1.0 μm
Warm up Time	4 minutes
Power Supply	AC100V, 550W
Dimensions	W11.8" x H13.8" x D25.6"
Weight	61.7 lbs (28 kg)



# Fluid Mechanics Research Instruments

## Smart LDV II Compact LDV System

Two ion lasers from the fiber optic transceiver probe detect velocity measurement. The Smart LDV System is an easy to use high quality LDV system.

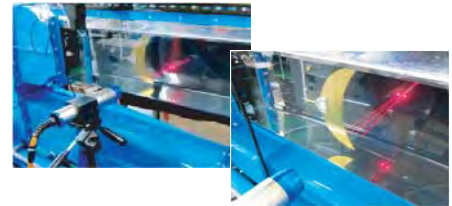
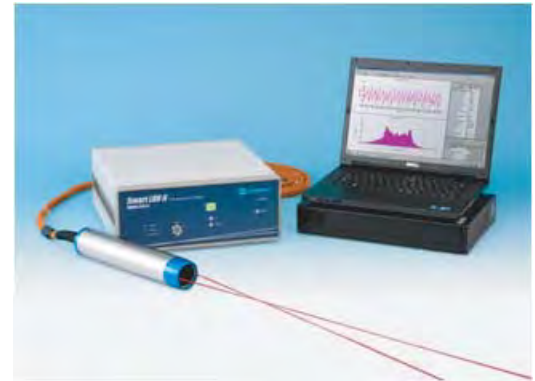
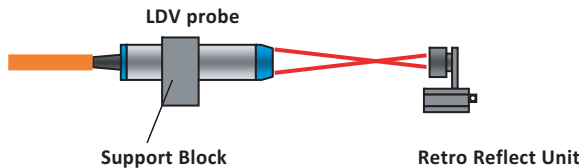

### Applications:

- Non-contact velocity measurements
- Wind tunnel studies
- Measurements in combustion, combustor

### Features:

- Measure velocity of each bubble
- Applicable for non-conductive fluid
- Signal Processor is available for option
- Includes LDV probe with cable, Smart LDV driver, BNC-BNC cable, Interlock connector, probe support block, power cable, and probe case

### Specifications

Model	Smart LDV II
Velocity Ranges	-40 to 100 m/s *Ask for above 100 m/s
Laser	Laser Diode: $\lambda = 660$ nm, Optical power: 60 mW
Focal Distance	150, 200, 250, 300, 350, 400mm
Focal Point Size	0.13 mm x 1.3 mm
Probe Size	$\varnothing 61$ mm x 312 mm
Shift Frequency	0.01 to 10 MHz (1-2-5 steps)
Signal Processing	8-bit FFT (512, 256, 128 points)
Max. Data Rate	16000 Data/sec

## FLUOSTAR

### Fluorescent Seeding Particles for PIV Applications

FLUOSTAR features outstanding emission efficiency of fluorescence, which is best suited for PIV applications. The strong orange-colored fluorescence may be even observed by sight using a 5 mW laser pointer.

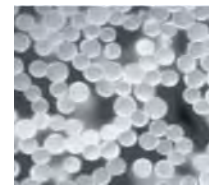

### Applications:

- Single-phase liquid flows
- Multi-phase flows
- Industrial large-scale flows
- Near-wall flows
- Stereo PIV

### Features:

- Moderate size dispersity
- Uniform spherical shape
- Minimal photobleaching
- Minimal dye leaking
- No swelling or shrinking

### Specifications

Substrate Material	Carboxy-modified acrylate resin
Refractive Index	1.560 (polymer)
Temperature	Resistant up to 100 Celsius (polymer)
Fluorescence dye	Rhodamine B (Excitation 550 nm / Emission 580 nm)
Density	1.1 g/cm <sup>3</sup>
Size Uniformity	15 um (Uniform spherical shape)
Size Uniformity	Less than 20% C.V.
Sizes	1, 5, and 10g



# Ultimate Measurement Instruments



HVAC Testing

Indoor Air Quality

Industrial Hygiene



Cleanroom Contamination Control

Industrial Flow Testing

Aerosol Research



Fluid Mechanics Research



Anemometers / Indoor Air Quality Monitors / Gas Monitors / Dust Monitors / Sound Meters / Vibration Meters / Particle Counters  
Cleanroom Monitoring System / Aerosol Research Instruments / Mass Spectrometer / Automotive Testing Instruments / Fluid Mechanics Research

# Open Jet Wind Tunnel

For airflow measuring instrument calibration

The general arrangement of the Open Jet Wind Tunnel covers the velocity range 0.3 to 30 m/s and is designed for bench mounting.

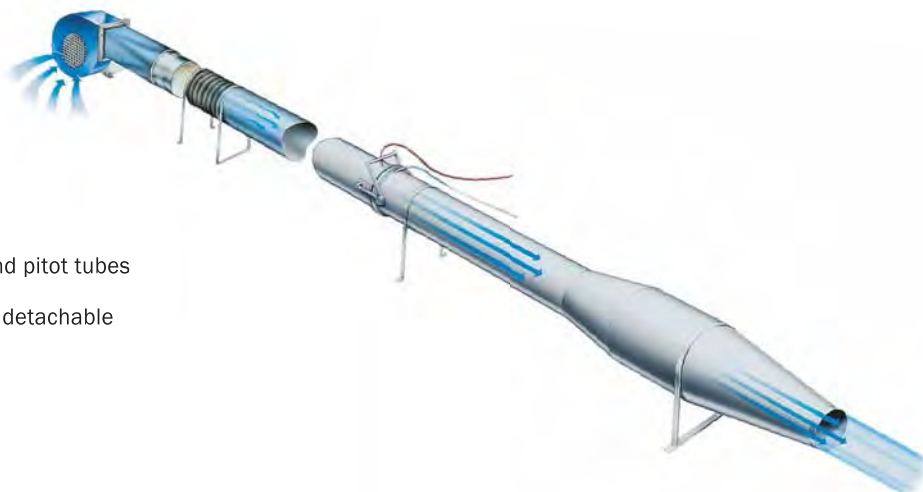

## Applications:

- Verification and calibration of anemometers and pitot tubes
- Capture hood calibration can be done with the detachable plenum chamber (option)
- NIST traceability
- Research and development

## Specifications

<b>Type</b>	Open Jet
<b>Velocity Range</b>	0.3 to 30 m/s
<b>Air Temperature</b>	Ambient
<b>Power Supply</b>	Single phase 220-240 V 50/60 Hz *Other Voltages can be supplied to suit country requirements
<b>Dimensions</b>	Length: 5500 mm (basic setup)



Wind Tunnel setup at Kanomax calibration lab

## ■ Schematic of the wind tunnel

The wind tunnel fan delivers air into a 200mm diameter tube containing piezometric flanges for the orifice plates forming a quick changeover orifice plate measurement device. Four orifice plates are supplied to cover the full velocity range settings.

Following the orifice plate device is an expansion chamber with perforated screens to provide an even air flow through a final contraction section. Terminating at a sharp edged exit nozzle to Atmosphere, the Air Jet is delivered at test velocity.

Fan with inverter speed controlled motor

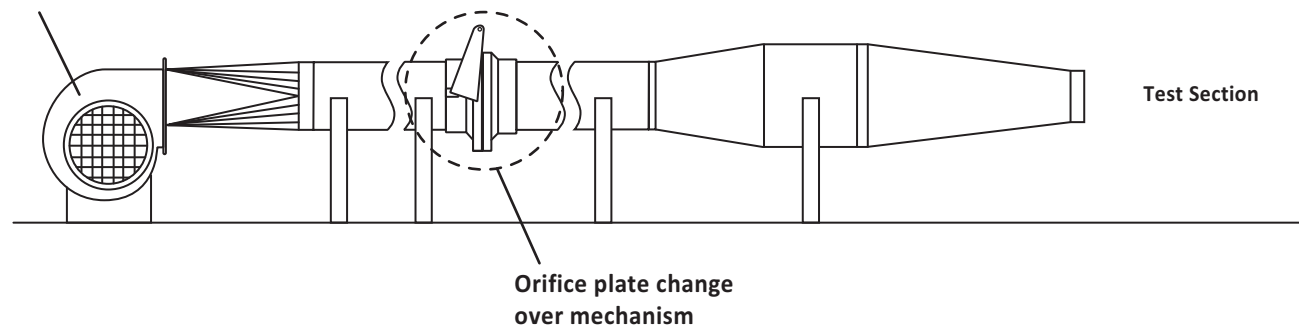

Orifice plate change over mechanism

Test Section



# Closed Circuit Wind Tunnel

For airflow measuring instrument calibration

Kanomax wind tunnel is designed for the calibration of anemometers and pitot static tubes. The wind tunnel has a velocity range of 0.5 to 50 m/s (98 to 9842 ft/min) and can also be used for small scale aerodynamic experiments.

### Applications:

- Verification and calibration of anemometers and pitot tubes
- NIST traceability
- Research and development



### Specifications

Type	Gottingen (closed circuit)
Velocity Range	0.5 to 50 m/s
Air Temperature	Ambient
Cross Section	150 x 150 mm
Power Supply	Tri-phase 380V 50Hz 6KVA
Dimensions	W3000 x H1600 x D1000 mm

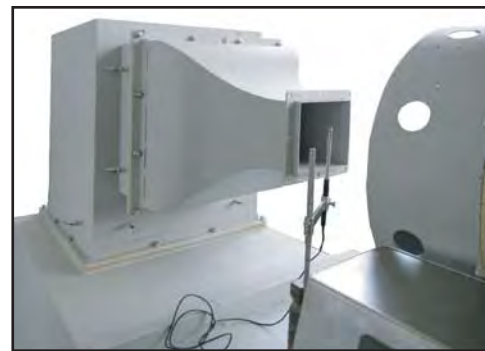

Test Section

### ■ Schematic of the wind tunnel

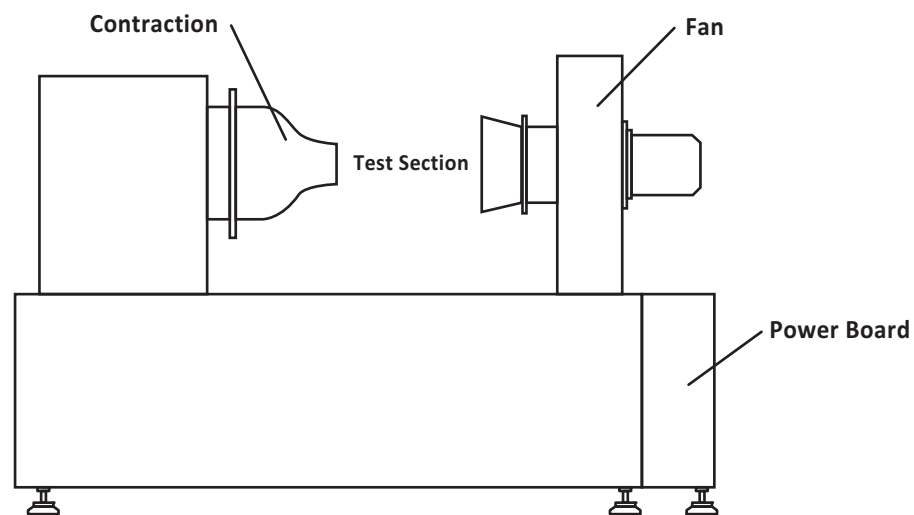

\*Kanomax offers other wind tunnel solutions. Please contact us.

## ■ Catalog Index

Aerosol Particle Mass Analyzers .....	Page 42
Airflow Transducers .....	Page 15
Air Velocity Meters / Anemometers .....	Page 3 - 16
Ambient Air Quality Monitor .....	Page 44
Amenity Manikin.....	Page 47
Black Carbon Monitor .....	Page 43
Cabin Leakage Testers .....	Page 48
Capture Hood .....	Page 9
Cleanroom Monitoring System.....	Page 39 - 40
Dif-Kit Tracer Gas Hardware.....	Page 22
Dust Monitors.....	Page 27 - 30
Flow Grids .....	Page 12
Fluidized Particle Generator.....	Page 44
Fluorescent Seeding Particles.....	Page 49
Flyash Sampler.....	Page 30
Gas Monitors.....	Page 19 - 21
Handheld Anemometers.....	Page 3 - 8
Handheld Condensation Particle Counter .....	Page 35
High Temperature Anemometer.....	Page 10
IAQ Monitors.....	Page 17 - 21
Inertial Filter.....	Page 43
Intelligent Hot Wire Anemometer.....	Page 50
Multi-channel Anemometers .....	Page 13 - 16
Networked Gas Sensor Systems.....	Page 21
Particle Counters.....	Page 31 - 38
Piezobalance Dust Monitor.....	Page 29
Pitot Static Tubes.....	Page 11
Rotating Vane Digital Anemometer.....	Page 8
Smoke Generator .....	Page 48
Smart LDV.....	Page 49
Sound Meter.....	Page 23 - 25
Thermohygrometer.....	Page 18
Time of Flight Mass Spectrometer .....	Page 46
Vapor Analyzer .....	Page 22
Vibration Meter.....	Page 26
Void Fraction Measuring System.....	Page 50
Wind Tunnel .....	Page 51 - 52

All specifications subject to change without prior notice



**Kanomax USA, Inc.**

Distributed by:

Contact:  
Industrial Process Measurement, Inc.  
3910 Park Avenue, Unit 7  
Edison, NJ 08820  
732-632-6400  
support@instrumentation2000.com  
<http://www.instrumentation2000.com>