

Application



The general purpose ultrasonic level switch provides continuous level detection up to 49.2" (1.25m) with 4 programmable relays for level switch or level control functions, and is configured via our free WebCal software. The embedded level controller can lower cost by replacing external control hardware. This non-contact liquid level sensor is ideally suited for corrosive, sticky or dirty liquids, and is broadly selected for small day tank, skid, IBC, sump and process tank level applications.



Features

- ✓ Level detection, switch and control functions up to 49.2" (1.25m)
- ✓ Configuration is fast and easy via WebCal software and USB adapter
- ✓ Narrow 2" beam width and short 2" dead band optimized for small tanks
- ✓ Four (4) programmable relays rated @ 1A / 60VA for switch, pump or valve control and fail-safety
 - 1 pump or valve with 3 alarms
 - 2 pumps (lead-lag) with 2 alarms
 - 2 pumps (duplexing) with 2 alarms
 - 4 independent switch point alarms
- ✓ PVDF transducer and 6P polycarbonate enclosure for corrosive liquids
- ✓ Automatic temperature compensation for accurate measurement

Success



Metal parts are often painted in dip tanks to achieve a clean, uniform coating. In this process, suspended parts are briefly submerged, and then removed

to rack dry in temperature and humidity controlled rooms. Dip tanks are generally 2' to 4' deep with level and mixer automation. Here an EchoPod multi-function level sensor controls the fill valve on each tank with a high and low level alarm. Additionally, the two-wire, 4-20 mA level measurement signal is monitored by the PLC. An optic level switch is also deployed as a redundant high level alarm.

Compatible Products

DataLoop™
Level Indicator



LI25

DataView™
Level Controller



LI55

Commander™
Multi-Tank Level Controller



LI90

DataPoint™
Level Controller



LC52

Specifications

Range: 49.2" (1.25m)
Accuracy: 0.125" (3mm)
Resolution: 0.019" (0.5mm)
Dead band: 2" (5cm)
Beam width: 2" (5cm)
Configuration: WebCal® PC
 Windows® USB 2.0
Memory: Non-volatile
Supply voltage: 12-24 VAC / VDC
Consumption: 0.5W
Contact type: (4) SPST relays, 1A
Contact fail-safe: Power loss: Hold last
 Power on: Open, close or hold last
Hysteresis: Selectable
Process temp.: F: 20° to 140°
 C: -7° to 60°
Temp. comp.: Automatic
Ambient temp.: F: -31° to 140°
 C: -35° to 60°
Pressure: MWP = 30 PSI (2 bar)
Enclosure rating: Type 6P, encapsulated, corrosion resistant & submersible
Encl. material: Polycarbonate
Strain relief mat: Santoprene
Trans. material: PVDF
Cable jacket mat: Polyurethane
Cable type: 9-conductor, shielded
Cable length: 48" (1.2m)
Process mount: 1" NPT (1" G)
Mount gasket: Viton®
Classification: General purpose
Compliance: CE, RoHS
Approvals: cFMus

Dimensions

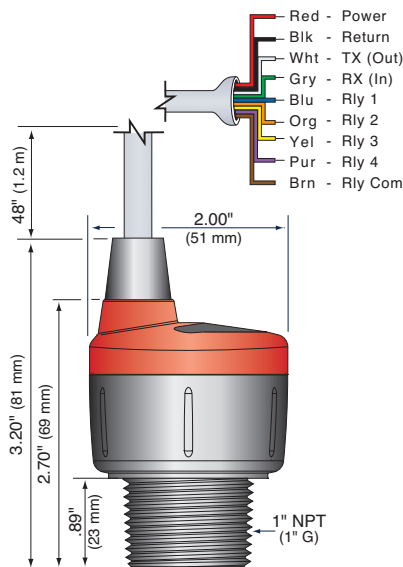

Configuration



The level sensor is configurable via our free WebCal PC software and Fob USB adapter. The sensors are offered with and without Fobs. Fobs are universal and can be used to configure any WebCal compatible product.

Download your free copy of WebCal in English or Chinese at www.flowline.com/webcal.php.

Fittings

For optimum performance, install the level sensor using the below recommended or direct equivalent fittings.

	P/N	Description
	LM52-1400	2" NPT x 1" NPT (Sch. 40)
	LM52-1800	2" NPT x 1" NPT (Sch. 80)
	LM52-1410	2" Socket x 1" NPT (Sch. 40)
	LM52-1810	2" Socket x 1" NPT (Sch. 80)
	LM52-1850	1" NPT Flange - 150# (Sch. 80)
	LM50-1001-1	1" NPT Bracket, Polypropylene

Ordering

DS14-

Process mount (1)

0 NPT (US)

1 G (Metric)

Fob USB adapter (2)

0 Without Fob

1 With Fob

Notes

- 1) Install the level sensor using Flowline installation fittings or equivalents.
- 2) The level sensor is configured via our WebCal software and one LI99-1001 Fob USB adapter. The level sensor is offered with and without a Fob. Fobs are universal and can be used to configure any WebCal compatible product. WebCal is a free download from our website at www.flowline.com/webcal.php.