

Type 1327CM Pressure Gauge Comparator



APPLICATION

- For pressure generation applications requiring a manually operated hydraulic pump

FEATURES

- Operating Pressure: 0-10,000 psi (maximum) (0-70,000 kPa)
- Operating Media:
- Standard: SAE 20 weight automotive or machine oil
- Optional: Phosphate-based or glycol fluids; Distilled water for oxygen service
- O-ring Material:
- Standard: Buna N (D Series)
- Optional: Ethylene Propylene (DH Series)
- Reservoir Volume: Approximately 1.5 pints (0.7 liter)

When greater accuracy is required but the convenience of a comparator is preferred, the 1327CM affords the best of both worlds in one complete set. Similar to the 1327D, the 1327CM provides the same pump, tools and accessories. However, to achieve greater accuracy the Ashcroft ¼% Test Gauges are replaced with from 1 to 3 Ashcroft Model A4A precision pressure gauges with a dial size of 6 inches.

Often regarded as the “ultimate master gauge,” the Ashcroft A4A precision pressure gauge yields consistent 0.1% of span accuracy in compliance with ASME B40.1, grade 4A. Each gauge is temperature compensated from -25 to +125°F and is provided with a Certificate of Calibration traceable to the NIST.

Since the quality of any calibration is dependent upon the integrity of the comparison standard, high accuracy comparator applications demand the best available master gauge. The 1327CM combines the proven accuracy of the Ashcroft precision pressure gauge with the established reliability of the Ashcroft Test Pump to produce one of the most accurate and versatile portable calibration systems available.

SPECIFICATIONS – 1327CM

Accuracy:	0.1% of gauge span
Gauges:	Ashcroft Model A4A, 6", ASME B40.1, Grade 4A, temperature compensated Bourdon tube material – 403SS or Beryllium Copper (depending on range) Gauge ranges – (see table)
Operating Pressure:	0 to 10,000 psi maximum (0 to 70,000 kPa)
Reservoir Volume:	Approximately 1.5 pints (0.7 liter)
Pump Body Material:	Aluminum alloy
Operating Fluid:	1327CMS – SAE 20 automotive or machine oil 1327CMH – Phosphate or glycol base hydraulic fluids 1327CMO – Distilled water (with sodium molybdate and phosphoric acid additives recommended as corrosion inhibitors)
O-Ring Seals:	Standard (1327CMS and 1327CMO) – Buna-N Optional (1327CMH) – Ethylene Propylene
Accessories:	Metal carrying and storage box Lower connection offset pipe assembly Back connection pipe Gauge pipe extension assembly ¼ & ½ NPT Female adapters Wrench (1" x 1½") Wrench (¾" x 1") Wrench (¾") Pointer puller set Installation and Operation Manual Spare O-ring kit
Certification:	Standard – NIST traceability document provided for each gauge
Carrying Case Dimensions:	10 x 10¼ x 22½ (inches)

Type 1327CM Pressure Gauge Comparator

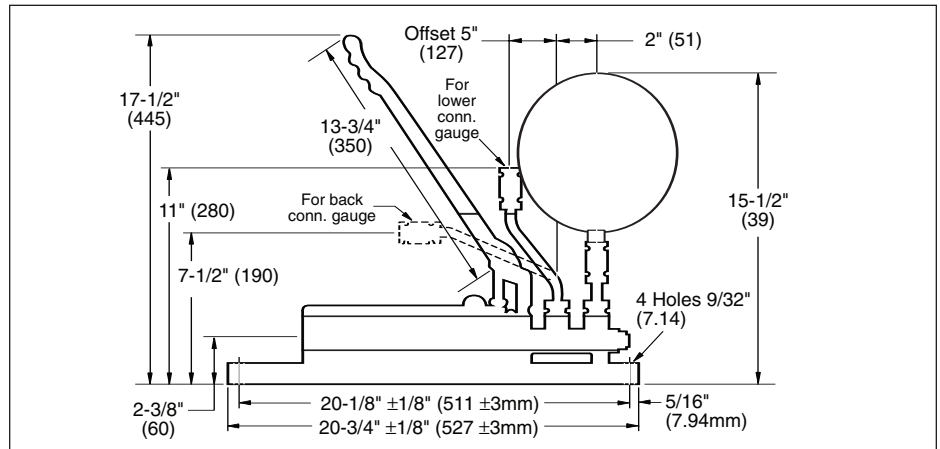

PRODUCT SELECTION CHART

Model	Media Designation (Choose 1)	Available Ranges (Choose 1, 2 or 3)
		No Gauges (X)
1327CM	Standard Oil Services (S)	psi 0-30 (A)
	Hydraulic Oil Services (H)	psi 0-100 (B)
	Oxygen Service (O)	psi 0-500 (C)
		psi 0-1000 (D)
		psi 0-5000 (E)
		psi 0-10,000 (F)
1327CM	Standard Oil Services (S)	bar 0-2 (G)
	Hydraulic Oil Services (H)	bar 0-10 (H)
	Oxygen Service (O)	bar 0-30 (J)
		bar 0-100 (K)
		bar 0-250 (L)
		bar 0-600 (M)
		kPa 0-200 (N)
		kPa 0-1000 (P)
		kPa 0-3000 (R)
		mPa 0-10 (S)
		mPa 0-25 (T)
		mPa 0-60 (U)