

## N-Series Electronic Pressure Switches



**IDEAL FOR PRESSURE ALARM, SHUTDOWN, CONTROL ON –**

- *Machine tools*
- *Injection molding machines*
- *Presses*
- *Pumps*
- *Hydraulic systems*
- *Turbines and compressors*
- *Pipelines*
- *Most process applications*
- *All high-cycle applications*

Ashcroft® N-Series electronic pressure switches have proven reliable in the toughest industrial applications. The pressure sensor is a standard Ashcroft K-Series thin film transducer. The signal developed in the transducer is processed on a conformal coated printed circuit board to produce an output to a high quality electromechanical relay, which is rated for 10,000,000 cycles at rated load! The result is a long lasting pressure switch that will outlast mechanical switches in high cycle applications such as metal stamping presses, plastic injection molding machines, and other machine tool and special equipment. N-Series also features narrow, adjust-able deadbands that can be adjusted to less than 0.5% of range, solving many pipeline and elevated tank applications that are out of the reach of mechanical products.

The indicating model is ideally suited for applications where both a pressure indicator and a switch output for alarm, shutdown, control or interlock are needed. Sludge and slurry applications in wastewater and pulp and paper mills often require costly diaphragm seals to isolate instruments from the clogging effects of the process. You can save money by installing N-Series with indication on a single seal. You can even set the switch set and reset points on a test bench without pressure on the system, using the indicator and status lights. Look for these additional features.

### PERFORMANCE SPECIFICATIONS

**Ashcroft Model:** N-Series

<b>Accuracy Class (F.S.):</b>	<b>1.0%</b>
Nonlinearity	
Terminal Point*	±0.7%
B.F.S.L.	±0.4%
Hysteresis	±0.2%
Nonrepeatability	±0.07%
Interchangeability	±1.0%

\*Includes hysteresis

**Stability:** ±0.5% F.S./year non-cumulative

**Durability:** 10<sup>8</sup> cycles 20/80% F.S. with negligible performance change

**Response time:** Less than 5m sec

### ENVIRONMENTAL CHARACTERISTICS

#### Temperature Limits:

Storage	–65/+250°F
Operating	–20/+180°F
Compensated	–20/+160°F

#### Thermal Coefficients (70°F ref.):

<u>Accuracy</u>	<u>Zero and Span</u>
1.0%	±0.040% F.S./°F

### ELECTRICAL SPECIFICATIONS

<b>Output Signal:</b>	<b>Supply Voltage:</b>
4-20mA (2 wire)	36 Vdc unregulated

**Reverse polarity protected.**

**Zero Offset:** ±1.0%F.S.

#### Load Limitations 4-20mA Output

Loop Resistance (Ω)

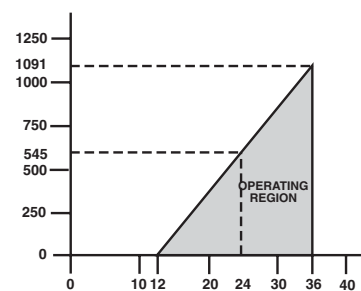

$$V_{min} = 12V + [.022A * (R_L)]$$

\*includes a 10% safety factor

$R_L = R_S + R_W$

$R_L =$  Loop Resistance (ohms)

$R_S =$  Sense Resistance (ohms)

$R_W =$  Wire Resistance (ohms)

# N-Series Electronic Pressure Switches

## N-SERIES PRESSURE SWITCH MODEL NUMBER:

To specify the exact switch desired select entries from appropriate tables as shown in example below.

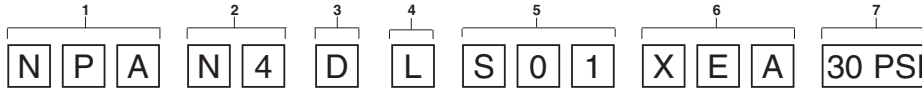

1 – FUNCTION		
<b>NPA</b>	Single setpoint, adjustable deadband	
<b>NPI</b>	Single setpoint, adjustable deadband, process and setpoint indication	

2 – ENCLOSURE		
<b>N4</b>	Watertight NEMA 3, 4, 4X, 13 and IP66	
<b>N7</b>	Explosion proof NEMA 3, 4, 4X, 13, 7, 9 and IP66 – Not available with Model NPI (display)	

3 – OUTPUT		
<b>D</b>	SPDT Relay	10A, 250 Vac 10A, 30 Vdc
<b>I</b>	SPDT Relay and Current Output	10A, 250 Vac 10A, 30 Vdc and 4-20mA

4 – POWER REQUIREMENT	
Code	
L	110 Vac, 50/60Hz
C	24 Vdc
V	250 Vac, 50/60Hz

5 – PRESSURE PORT	
Code	Description
<b>S01</b>	1/8 NPT Male
<b>S02</b>	1/4 NPT Male
<b>S03</b>	1/8 NPT Female
<b>S04</b>	1/4 NPT Female
<b>S05</b>	7/16-20 SAE-1/4 SAE
<b>S06</b>	1/2 NPT Male 1/4 & NPT Female
<b>S07</b>	1/4 AMINCO – Female

6 – N-SERIES OPTIONS	
CODE	DESCRIPTION
XEA	External setpoint adjustment Consult factory for other options

7 – NOMINAL RANGE			
PERFORMANCE TABLE (psi)			
Nominal Range	Setpoint Limits	psi Proof	psi Burst
60	3-60	120	480
100	5-100	200	800
200	10-200	400	1600
300	15-300	600	2400
500	25-500	1000	4000
750	35-750	1500	6000
1000	50-1000	2000	8000
2000	100-2000	4000	16,000
3000	150-3000	4500	20,000
5000	250-5000	7500	22,500
7500	375-7500	9000	25,000
10,000	500-10,000	12,000	30,000
15,000	750-15,000	18,000	45,000
20,000	1000-20,000	24,000	60,000

### NOTE: TEMPERATURE SPECIFICATIONS (70°F ref.)

-20°F to 160°F  
Setpoint shift of up to 2% of range per 50°F change can be expected

## DIMENSION DRAWINGS

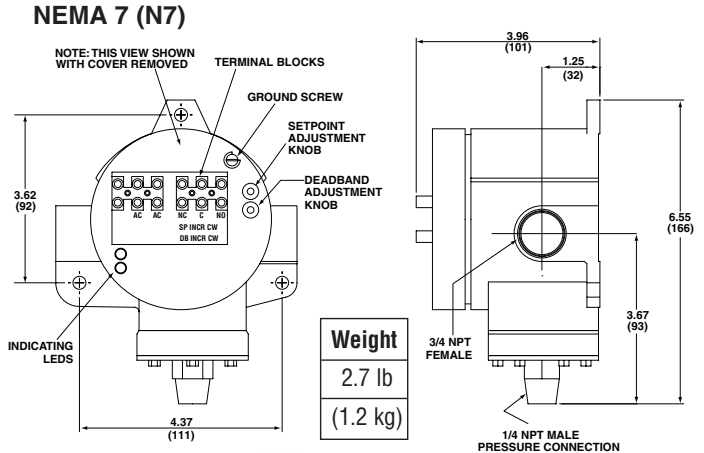
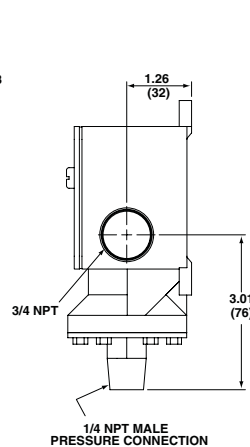
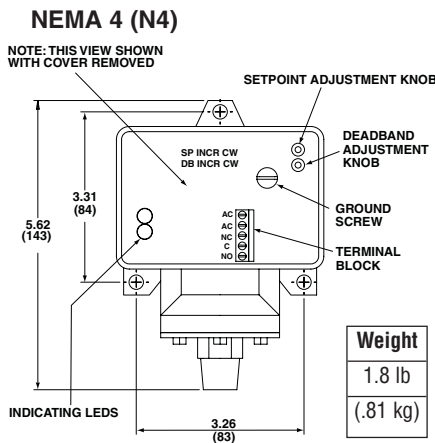

All specifications are subject to change without notice.  
All sales subject to standard terms and conditions.  
© Ashcroft Inc. 2007 8/07

Contact:  
Industrial Process Measurement, Inc.  
3910 Park Avenue, Unit 7  
Edison, NJ 08820  
732-632-6400  
support@instrumentation2000.com  
http://www.instrumentation2000.com