

P-Series Differential Pressure, Pressure & Temperature Switches



FEATURES

- **Explosion Proof and Watertight Enclosure – N7 Models**
- **Easy-to-read scale for approximate setpoint indication ($\pm 5\%$ accuracy)**
- **Stainless steel internal parts**
- **Easy setpoint adjustment(s) capability**
- **Diaphragm-sealed piston actuator for long life is standard for most ranges**

Ashcroft® switches and controls are highly reliable for your industrial and process applications. We begin with rock-solid designs, matching the most appropriate technology with the safety and reliability requirements of the applications. The materials of construction are specified to exacting standards, and product is built to last in the toughest applications. Our modern, responsive manufacturing facility is supported by an extensive network of stocking distributors and factory sales offices located in virtually every part of the world. Special application assistance is always just a telephone call away. The Ashcroft P-Series switch line is designed for uncompromising end user reliability and safety.

Die cast aluminum enclosure is available in NEMA 7/9 (explosion-proof enclosure Class I, Div. 1 & 2, Groups B, C, & D and Class II, Div. 1 & 2, Groups E, F and G). Dual chamber design allows setpoint changes to be made safely even with power connected. Materials of construction have been selected for long life. A wide variety of precision switch elements are available to meet every application requirement, including hermetically sealed contacts for added reliability and safety. The actuators we use have been proven in more than twenty years of service in plants and mills throughout the world. Multiple features such as dual setpoints and adjustable deadbands are offered. Special designs are available for fire safety, limit control and other more stringent requirements. Ease of use is stressed to improve the reliability of the installation.

P-Series switches are currently being successfully used in refineries, chemical and petrochemical plants, water and sewage treatment plants, steel mills and other tough applications. Typical applications are on blowers, compressors, boilers, burners, turbines and reverse osmosis systems.

Thermowells

Thermowells must be used on any application where the stem of the temperature switch may be exposed to pressure, corrosive fluids or high velocity. Additionally, the use of a thermowell permits instrument interchange or calibration check without disturbing or closing down the process.

Ashcroft temperature switches have bulb diameters to match $\frac{3}{8}$ " nominal bore thermowells. The bulbs have a sensitive portion length of 2" which can be used with $2\frac{1}{2}$ " "U" dimensioned thermowells or longer. For maximum accuracy, a thermowell's "U" dimension should be selected to permit complete immersion of the sensitive portion plus 1" when measuring the temperature of liquids; an extra 3" should be allowed when measuring the temperature of gases.

Thermowell bushings should be used with remote mount temperature switches. We recommend the standard 3" bulb and code 69 Series bushings for use with any thermowell "U" dimension. A split rubber grommet allows easy installation and "S" dimension adjustment.

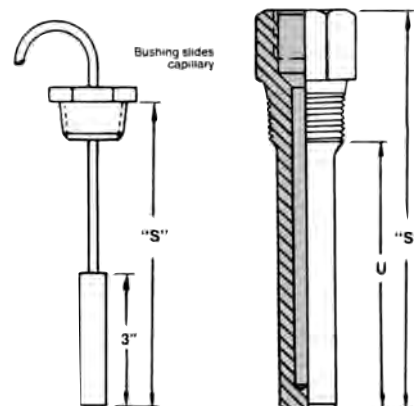

P-Series Differential Pressure, Pressure & Temperature Switches

Temperature Switches

P-Series temperature switches feature a SAMA Class II vapor pressure thermal system. This system provides quick, accurate response to process temperature changes with negligible ambient temperature effects. This is inherent in the design due to the precise relationship that exists between temperature

and pressure according to the vapor pressure laws. A wide selection of sensing bulb and armored capillary lengths are available. The vapor pressure system design features small bulb sizes, making installation easy and cost-effective.

All models feature $\pm 1\%$ percent of span set point repeatability with very

high overtemperature ratings.

These standard designs perform well in applications where shock and vibration could be a problem and should be used with Ashcroft thermowells for bulb protection and ease of installation and maintenance.

STANDARD TEMPERATURE RANGE SELECTION

APPROXIMATE DEADBAND

NOMINAL RANGE		MAX. TEMP. °F	APPROXIMATE DEADBAND								
			PTA ⁽⁴⁾			PTS ⁽⁴⁾			PTD ⁽⁴⁾		
°F	°C		SWITCH ELEMENT								
			J,H	G	J,H	K,F	P	GG	JJ,HH	KK,FF	PP
-40 to 60	-40 to 16	400	18-90	2-10	9-18	1-2	1-5	2-10	9-18	1-2	1-5
0 to 100	-20 to 40	400	30-90	2-15	10-30	1-3	1.5-7	2-15	10-30	1.5-3	1.5-7
75 to 205	20 to 95	400	34-120	2-17	10-34	1.5-3.5	1.5-8	2-17	10-34	1.5-3.5	1.5-8
150 to 260	65 to 125	400	25-100	2.5-12	9-25	1-2.5	1-7	2.5-12	9-25	1-2.5	1-7
235 to 375	110 to 190	500	35-130	2-18	10-35	1-3.5	1.5-8	2-18	10-35	1-3.5	1.5-8
350 to 525 ⁽⁶⁾	175 to 275	700	40-165	3-25	15-40	2-4.5	2.5-11	3-25	15-40	2-4.5	2.5-11
500 to 750 ⁽⁵⁾	260 to 400	900	50-200	20-36	36-60	5-10	6-21	20-36	36-60	5-10	6-21

- NOTES:**
- 1 All deadbands are in °F.
 - 2 Switches can be set at increase or decrease throughout the nominal range.
 - 3 Deadbands for PTA models are adjustable between the values shown.
 - 4 Deadbands for PTS and PTD models are fixed within the range of values shown. Manufacturing and parts variances result in variation from one unit to another as shown.
 - 5 Available with remote mount thermal systems only.
 - 6 Not available with 2 3/4" stem.

P-Series Differential Pressure, Pressure & Temperature Switches

Pressure & Differential Pressure Switches

P-Series pressure, differential pressure and vacuum switches use two different actuators depending on setpoint requirements. For setpoints between 2 and 3000 psi, the simple, rugged diaphragm-sealed piston actuator is used. This design features high reliability and a choice of actuator seal materials for virtually every application. An optional welded design is also available for setpoints up to 1000 psi

for maximum reliability. This design is available in 316 SS or Monel. Differential pressure models use a unique dual-diaphragm-sealed piston design that features very high static operating pressures and small size.

For setpoints between 4.5 and 150 inches of H₂O, a large diaphragm is used for increased sensitivity in both pressure and differential pressure designs with good choice

of materials of construction.

All standard models feature ± 1 percent of range setpoint repeatability and a minimum of 400 percent of range proof pressures.

These standard designs perform well in applications where shock and vibration could be a problem and may be used with Ashcroft® diaphragm seals in extreme services such as slurries or abrasive process fluids.

PRESSURE/VACUUM SWITCHES

APPROXIMATE DEADBAND⁽²⁾ (BUNA-N DIAPHRAGM)

NOMINAL RANGE ⁽¹⁾			Overpressure Ratings		PPA ⁽³⁾		PPS ⁽⁴⁾					PPD ⁽⁴⁾		
			Proof psi	Burst psi	SWITCH ELEMENT									
					J,H	G	J,H	K,F	P	GG	JJ,HH	KK,FF	PP	
VACUUM	-30" Hg	-760mm Hg	-100 Kpa	250	400	7-26	3-5	3-6.5	1-2	1-2.5	3-5	3-6.5	1-2	1-2.5
COMPOUND	30" Hg/ 15 psi	760mm Hg/ 1.0 Kg/cm ²	-100 Kpa 100 Kpa	250	400	10-25 4-13	3-5 1-2	2.5-3.5 1-3	1-2 0.5-1	1-2.5 0.5-1.2	3-5 2-4	2.5-4.5 1-3	1-2 0.5-1	1-2.5 0.5-1.2
PRESSURE	30" H ₂ O	750mm H ₂ O	7.5 Kpa	20	35	4-27	1.5-3.5	2-5	0.5-1	0.5-2	1.5-3.5	2-5	0.5-1	0.5-2
	60" H ₂ O	1500mm H ₂ O	15 Kpa	20	35	5-54	1.5-3.5	2.5-5	0.5-1.3	1-2	1.5-3.5	2.5-5	0.5-1.3	1-2
	100" H ₂ O	2500mm H ₂ O	25 Kpa	20	35	8.5-90	4-6	4-8.5	1-2	1-3	4-7	4-8.5	1-2	1-3
	150" H ₂ O	3750mm H ₂ O	37 Kpa	20	35	18-135	5-11	10-18	1.5-3	2-6	8-14	10-18	1.5-3	2-6
	15 psi	1.0 kg/cm ²	100 Kpa	500	1000	2.5-13	1-2	1-3	0.5-1	0.5-1.2	1-2	1-3	0.5-1	0.5-1.2
	30 psi	2.0 kg/cm ²	200 Kpa	500	1500	3-26	1-2.5	2-4.5	0.5-1.5	0.5-1.5	1-2.5	2-4.5	0.5-1.5	0.5-1.5
	60 psi	4.0 kg/cm ²	400 Kpa	500	1500	5-54	2-4	4-7	1-2	1-2.5	2-4	4-7	1-2	1-2.5
	100 psi	7.0 kg/cm ²	700 Kpa	1000	3000	10-90	5-7	5-10	1-2.5	2-4	5-7	5-10	1-2.5	2-4
	200 psi	14 kg/cm ²	1400 Kpa	1000	3000	20-180	10-15	10-18	1-4	5-8	10-20	15-35	3-6	5-8
	400 psi	28 kg/cm ²	2800 Kpa	2400	3000	45-360	16-30	16-45	4-8	5-15	16-30	16-45	4-8	5-15
	600 psi	42 kg/cm ²	4200 Kpa	2400	3000	75-540	16-50	20-75	5-15	6-25	16-50	20-75	5-15	6-25
	1000 psi ⁽⁵⁾	70 kg/cm ²	7000 Kpa	12000	14000	160-900	75-130	50-160	7-30	10-85	75-130	50-160	7-30	10-85
	2000 psi	140 kg/cm ²	14000 Kpa	12000	14000	350-1800	150-200	150-350	20-50	25-110	150-200	150-350	20-50	25-110
	3000 psi	210 kg/cm ²	21000 Kpa	12000	14000	400-2600	180-250	180-400	30-70	50-250	180-250	180-400	30-70	50-250

DIFFERENTIAL PRESSURE SWITCHES

APPROXIMATE DEADBAND⁽²⁾ (BUNA-N DIAPHRAGM)

NOMINAL RANGE ⁽¹⁾			Overpressure Ratings		PDA ⁽³⁾		PDS ⁽⁴⁾					PDD ⁽⁴⁾	
			Static Working Pressure	Proof psi	SWITCH ELEMENT								
					J,H	G	J,H	K,F	P	GG	JJ,HH	KK,FF	PP
30" H ₂ O Diff.	750mm H ₂ O	5.4	21.6	5.5-27	3-5	4-6.5	0.5-1	0.5-2	3-5	4-6.5	0.5-1	0.5-2	
60" H ₂ O Diff.	1500mm H ₂ O	5.4	21.6	5.5-54	3-5	4.5-6.5	0.5-1.3	1-2	3-5	4-6.5	0.5-1.3	1-2	
100" H ₂ O Diff.	2500mm H ₂ O	5.4	21.6	8.5-90	4-6	4.5-8.5	1-2	1-3	4-7	4-8.5	1-2	1-3	
150" H ₂ O Diff.	3750mm H ₂ O	5.4	21.6	18-135	5-11	10-18	1.5-3	2-6	8-12	10-18	1.5-3	2-6	
15 psid	1.0 kg/cm ²	500	2000	2.5-13	1-2	1-3	0.5-1	0.5-1.2	1-2	1-3	0.5-1	0.5-1.2	
30 psid	2.0 kg/cm ²	500	2000	3.5-27	1-2.5	2-4.5	1-1.5	1-1.5	1-2.5	2-4.5	0.5-1.5	0.5-1.5	
60 psid	4.0 kg/cm ²	500	2000	6.5-54	2-4	4-7	1-2	1-2.5	2-4	4-7	1-2	1-2.5	
100 psid	7.0 kg/cm ²	1000	4000	10-90	5-7	5-10	1-2.5	2-4	5-7	5-10	1-2.5	2-4	
200 psid	14 kg/cm ²	1000	4000	20-180	10-15	10-18	1-4	5-8	10-20	10-18	3-6	5-8	
400 psid	28 kg/cm ²	1000	8000	45-360	16-30	16-45	4-8	5-15	16-30	16-45	4-8	5-15	

Values shown are for 0 static working pressure

NOTES:

- Switches may generally be set between 15% and 100% of nominal range on in-creasing pressure. Consult factory for applications where set points must be lower.
- All deadbands are given in English units as shown in the nominal range column. Deadbands shown are for switches with Buna N diaphragm.

- Approximate deadbands for optional diaphragms:
- Viton: Multiply Buna N value by 1.4
 - Teflon: Multiply Buna N value by 1.2
 - Stainless Steel: Multiply Buna N value by 1.7
 - Monel: Multiply Buna N value by 1.7

- Deadbands for PPA and PDA models are adjustable between

- the values shown.
- Deadbands for PPS, PPD, PDS and PDD models are fixed within the range of values shown. Manufacturing and parts variances result in variation from one unit to another as shown.
 - Proof pressure is 4000 psi with SS and Monel welded diaphragms.

P-Series Differential Pressure, Pressure & Temperature Switches

P-SERIES PRESSURE AND DIFFERENTIAL PRESSURE SWITCH MODEL NUMBER:

To specify the exact switch desired select entries from appropriate tables as shown in example below.

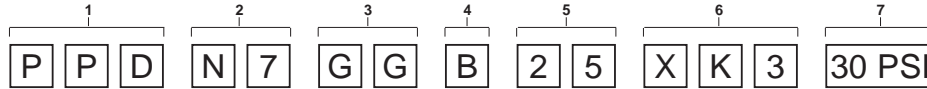

1 – FUNCTION	
PPA	Pressure control, single setpoint, adjustable deadband
PPD	Pressure control, two independently adjustable setpoints, fixed deadband
PPS	Pressure control, single setpoint, fixed deadband
PDA	Differential pressure control, single setpoint, adjustable deadband
PDD	Differential pressure control, two independently adjustable setpoints, fixed deadband
PDS	Differential Pressure control, single setpoint, fixed deadband

2 – ENCLOSURE	
N7-NEMA 7&9, IP66 (explosion proof Div. 1 & 2)	

3 – SWITCH ELEMENTS FOR PPA & PDA CONTROLS

CODE	S.P.D.T. Switch Elements UL/CSA Listed	
H	General Purpose	10A, 125/250 Vac 1/2A, 125 Vdc 1/4A, 250 Vdc
J	Hermetically Sealed Switch, General Purpose	11A, 125/250 Vac 5A, 30 Vdc

SWITCH ELEMENTS FOR PPD, PPS, PDD AND PDS CONTROLS

CODE		Switch Elements UL/CSA Listed	
Single (PS)	Dual (PD)		
C	CC	Heavy Duty – AC	22A, 125/250 Vac
E	EE	Manual Reset, Actuates on Decreasing Pressure	15A, 125/250 Vac 5A, 30 Vdc
F ⁽⁴⁾	FF	Sealed Environment Proof	15A, 125/250 Vac
G ⁽⁵⁾	GG	General Purpose	15A, 125/250/480 Vac 1/2A, 125 Vdc 1/4A, 250 Vdc
H	HH	General Purpose – AC-DC	10A, 125/250 Vac 10A, Vdc
J	JJ	Hermetically Sealed Switch, General Purpose	11A, 125/250 Vac 5A, 30 Vdc
K ⁽⁴⁾	KK	Narrow Deadband	15A, 125/250 Vac
L	LL	Hermetically Sealed, Gold Contacts	1A, 125 Vac
M	MM	Low Level Gold Contacts	1A, 125 Vac
P(3)	PP	Hermetically Sealed – AC	5A, 125/250 Vac
U	UU	Manual Reset, Actuates on Increasing Pressure	15A, 125/250 Vac 6A, 130 Vdc
W	WW	Ammonia Service	5A, 125/250 Vac 6A, 30 Vdc
Y	YY	High Temperature 300°F Ambient	15A, 125/250 Vac
S	SS	Heavy Duty – DC	10A, 125 Vac or Vdc 1/8 HP, 125 Vac or Vdc

NOTES:

- 1 These items are wetted by process fluid.
- 2 Ambient operating temperature limits –20 to 150°F, all styles. Set point shift of range per 50°F temperature change is normal.
- 3 Estimated dc rating, 2.5A, 28 Vdc (not UL listed).
- 4 Estimated dc rating, .4A, 120 Vdc (not UL listed).
- 5 Not UL listed at 480 Vac.

- 6 Supply static pressure for D/P switches.
- 7 St. diaphragm only.
- 8 Not available with Buna-N diaphragm.
- 9 Available on psi only.
- 10 Not available on NEMA 7.
- 11 Available with Teflon diaphragm only, to 600 psi only.

4 – ACTUATOR SEAL™					
Code and Material	Process Temp. Limits °F ⁽²⁾	Range			
		VAC ~ H ₂ O	0-600 psi	1000 psi	2000-3000 psi
B – Buna-N	0 to 150	•	•	•	•
V – Viton	20 to 300	•	•	•	•
T – Teflon	0 to 150	•	•	•	•
S – SS ⁽⁹⁾	0 to 300	•	•	•	•
P – Monel ⁽⁹⁾	0 to 300	•	•	•	•

5 – PRESSURE PORT	
Code	
25	¼" NPT Female (Std. up to 1000#)
06	¼" NPT Female and ½" NPT Male Combination
07	½" NPT Female

6 – P-SERIES OPTIONS

CODE	DESCRIPTION	Pressure		Differential Pressure	
		psi	~ H ₂ O	psi	~ H ₂ O
XCH	Chained Cover	•	•	•	•
XC8 ⁽¹⁰⁾	CSA Approval, N7	•	•	•	•
XD2	Dual Seal Rating	•	N/A	N/A	•
XFP	Fungus Proofing	•	•	•	•
XFS ⁽⁶⁾	Factory Adjusted Setpoints	•	•	•	•
XG9 ⁽⁷⁾	Fire Safe Actuator	•	N/A	N/A	N/A
HXH	40 psi Static Press. (D/P Only)	N/A	•	N/A	•
	160 psi Proof Press. (D/P Only)				
	100 psi Proof Press. (Press. Only)				
XJL	¾" to ½" Reducing Bushing	•	•	•	•
XK3	Terminal Blocks	•	•	•	•
XL9 ⁽¹¹⁾	Low Hardness SS Pressure Conn.	•	N/A	N/A	N/A
XNH	Tagging Stainless Steel	•	•	•	•
XPK ⁽¹⁰⁾	Pilot Light(s)	•	•	•	•
XPM	¾" Sealed Conduit Conn. with 16" Lead Wires	•	•	•	•
XTA	316 SS Press. Conn. for ~H ₂ O Ranges	N/A	•	N/A	•
XUD	316 SS Press. Conn. for psid Ranges	N/A	N/A	•	N/A
X6B ⁽⁶⁾	Cleaned for Oxygen Service	•	N/A	•	N/A

7 – RANGE	
Select from Table on Page 2	

All specifications are subject to change without notice.
All sales subject to standard terms and conditions.
© Ashcroft Inc. 2007 8/07

P-Series Differential Pressure, Pressure & Temperature Switches

P-SERIES TEMPERATURE SWITCH MODEL NUMBER:

To specify the exact switch desired select entries from appropriate tables as shown in example below.

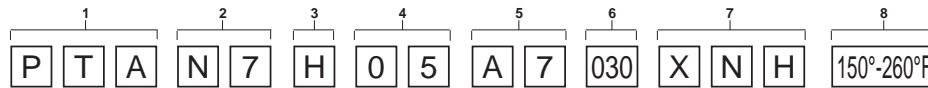

1 – FUNCTION
PTA – Temperature control, single setpoint, adjustable deadband
PTD – Temperature control, two independently adjustable setpoints, fixed deadband
PTS – Temperature control, single setpoint, fixed deadband

2 – ENCLOSURE
N7-NEMA 7, 9, IP66 (explosion proof Div.1 & 2)

4 – LINE LENGTH ⁽²⁾		
Direct Mount		
ORDER CODE	Line Length	Style
00	Not Applicable	Rigid
Remote Mount		
05	5'	Capillary with Armor (Std.)
10	10'	
15	15'	
20	20'	
25	25'	

5 – THERMAL SYSTEM SELECTION ⁽¹⁾	
LINE MATERIAL	
Direct Mount	
ORDER CODE	DESCRIPTION
	No Entry Required for Direct Mount
Remote Mount	
A7	SS Armor (Std.)

3 – SWITCH ELEMENTS FOR PTA CONTROLS			
S.P.D.T. Switch Elements UL/CSA Listed			
CODE			
H	General Purpose		10A, 125/250 Vac 1/2A, 125 Vdc 1/4A, 250 Vdc
J	Hermetically Sealed Switch, General Purpose		11A, 125/250 Vac 5A, 30 Vdc
SWITCH ELEMENTS FOR PTD AND PTS CONTROLS			
CODE		Switch Elements UL/CSA Listed	
Single (PS)	Dual (PD)		
C	CC	Heavy Duty – AC	22A, 125/250 Vac
E	EE	Manual Reset, Actuates on Decreasing Pressure	15A, 125/250 Vac 5A, 30 Vdc
F ⁽⁴⁾	FF	Sealed Environment Proof	15A, 125/250 Vac
G ⁽⁵⁾	GG	General Purpose	15A, 125/250/480 Vac 1/2A, 125 Vdc 1/4A, 250 Vdc
H	HH	General Purpose – AC-DC	10A, 125/250 Vac 10A, Vdc
J	JJ	Hermetically Sealed Switch, General Purpose	11A, 125/250 Vac 5A, 30 Vdc
K ⁽⁴⁾	KK	Narrow Deadband	15A, 125/250 Vac
L	LL	Hermetically Sealed, Gold Contacts	1A, 125 Vac
M	MM	Low Level Gold Contacts	1A, 125 Vac
P ⁽³⁾	PP	Hermetically Sealed – AC	5A, 125/250 Vac
U	UU	Manual Reset, Actuates on Increasing Pressure	15A, 125/250 Vac 6A, 130 Vdc
W	WW	Ammonia Service	5A, 125/250 Vac 6A, 30 Vdc
Y	YY	High Temperature 300°F Ambient	15A, 125/250 Vac
S	SS	Heavy Duty – DC	10A, 125 Vac or Vdc 1/8 HP, 125 Vac or Vdc

NOTES:

- All thermal systems are 316 St. St.
- Additional line lengths available, consult factory.
- Additional bulb lengths available, consult factory.
- Additional ranges available, consult factory.
- Estimated dc rating, 2.5A, 28Vdc (not UL listed).
- Estimated dc rating, .4A, 120 Vdc (not UL listed).
- Not UL listed at 480 Vac.
- See page 5 for thermowell application information.
- Standard on N4 enclosure.
- Not available in 350/5250F range.

6 – BULB LENGTH SELECTION ⁽³⁾		
Direct Mount		
ORDER CODE	"S" DIM.	MIN. ⁽⁸⁾ THERMOWELL "U" DIM.
027 ⁽¹⁰⁾	2¾"	–
040	4"	2½"
060	6"	4½"
090	9"	7½"
120	12"	10½"
Remote Mount		
030	3"	2½"

7 – P-SERIES OPTIONS	
CODE	DESCRIPTION
XCH	Chained Cover
XC8 ⁽⁹⁾	CSA Approval, N7
XFP	Fungus Proof
XFS	Factory Adjusted Setpoints
XJL	¾" to ½" Reducing Bushing
XK3	Terminal Blocks
XNH	Tagging Stainless Steel
XPK	Pilot Light(s)
XPM	¾" Sealed Conduit Connection with 16" Lead Wires
XBX	69 Series Bushing for Thermowell System. ½ Male NPT

8 – STANDARD TEMPERATURE RANGE SELECTION ⁽⁴⁾
Select from Table on Page 2

All specifications are subject to change without notice.
All sales subject to standard terms and conditions.
© Ashcroft Inc. 2007 8/07

P-Series Differential Pressure, Pressure & Temperature Switches

Dimensions – P-Series

Temperature Switch – Direct Mount

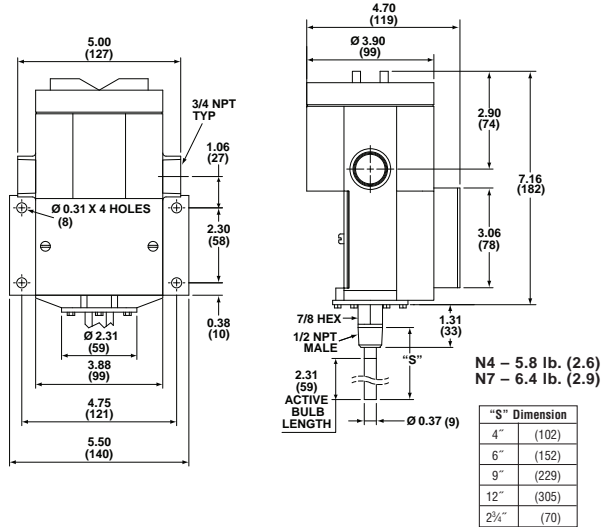

Pressure Switch – psi Ranges

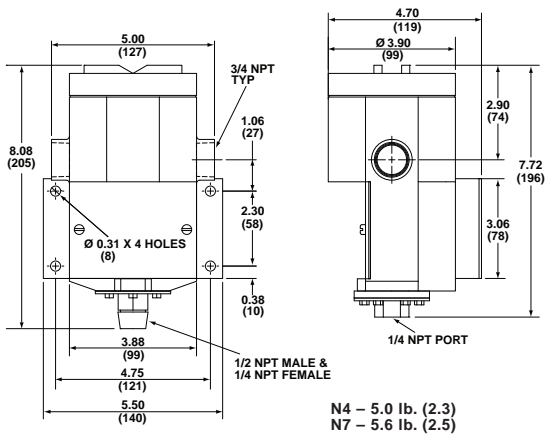

Differential Pressure Switch – psid Ranges

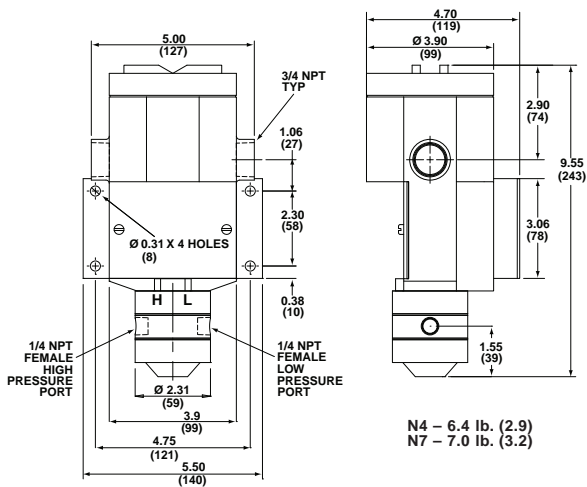

All specifications are subject to change without notice.
 All sales subject to standard terms and conditions.
 © Ashcroft Inc. 2007 8/07

P-Series Differential Pressure, Pressure & Temperature Switches

Dimensions – P-Series

Temperature Switch – Remote Mount

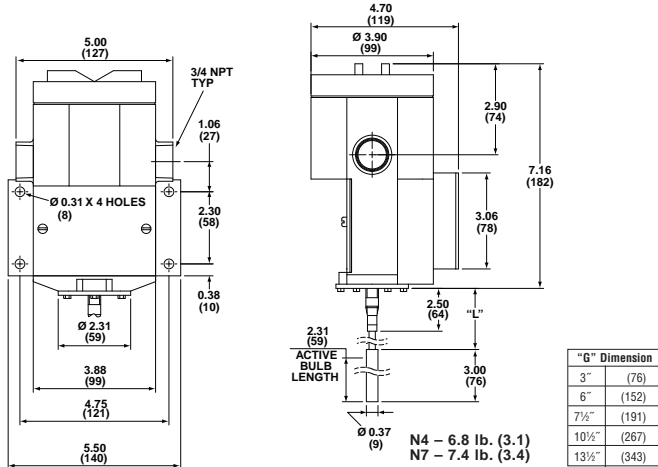

Pressure Switch – in. H₂O Ranges

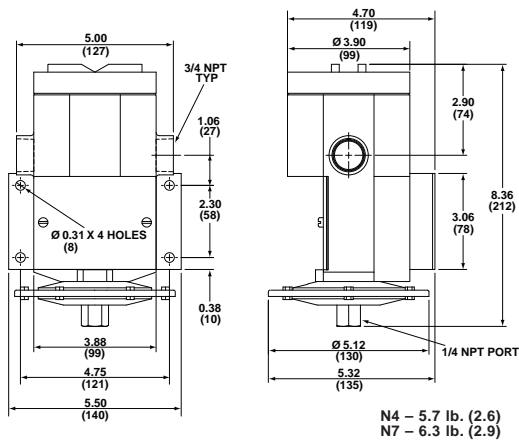

Differential Pressure Switch – Diff. in. H₂O Ranges

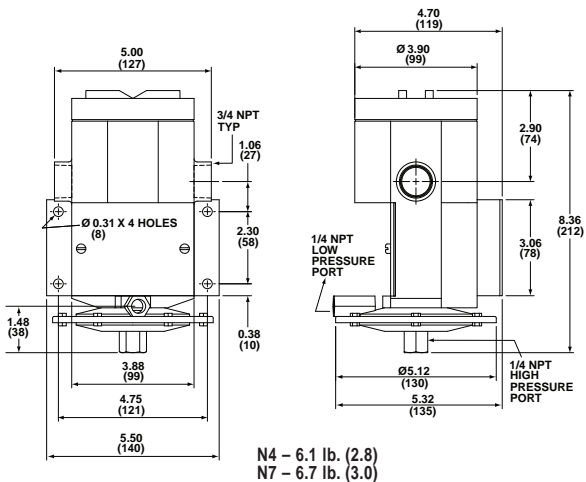

Contact:
Industrial Process Measurement, Inc.
3910 Park Avenue, Unit 7
Edison, NJ 08820
732-632-6400
support@instrumentation2000.com
<http://www.instrumentation2000.com>

All specifications are subject to change without notice.
All sales subject to standard terms and conditions.
© Ashcroft Inc. 2007 8/07