

**Pressure Range**

1 to 2,000 kPa (0.145 to 300 psi)

**Accuracy**

to  $\pm 0.015\%$  of Indicated reading  
Accuracy  $\pm 0.025$  and  $0.050\%$  is also available

**Repeatability**

$\pm 0.005\%$  of indicated reading

**Available units**

psi, kg/cm<sup>2</sup>, bar, kPa, inH<sub>2</sub>O, cmH<sub>2</sub>O, inHg

**Special Calibrations/Local Gravity**

RK testers are supplied standard with masses calibrated to International Standard gravity of 9.80665 m/s<sup>2</sup>. Local gravity calibration is available on all models.

**Gas Industry Models**

Standard testers in inH<sub>2</sub>O or cmH<sub>2</sub>O are calibrated reference water columns at 20°C (68°F) per ISA recommended practices. Calibration to reference water columns at 60°F per AGA standards is available.

**Exceptional Performance and Safety Built-In**

- Floating Ball Operation
- Self-Regulating
- Rugged Ceramic Measuring Ball
- Overhung Weight Carrier
- Non-Contaminating Test Fluid
- Closed Cover Operation
- Ball Valves for Inlet and Outlet
- Interchangeable Weights
- NIST Traceable

ISO 9001 Manufacturer

## Model RK

**Pneumatic Deadweight Tester****PRODUCT DESCRIPTION**

The RK tester is a floating ball type, pneumatic deadweight tester. This model is engineered to offer user-friendly features, safe operation, and an optimal performance in the field or in the lab.

**Self-regulating pressure standard**

The AMETEK RK Pneumatic Deadweight Tester is a primary standard that produces a pressure by applying force (weight set) over area (the ceramic ball and nozzle). The RK tester is NIST traceable and accurate to  $\pm 0.015\%$  using stainless steel weights calibrated to International standard gravity at 9.80665 m/s<sup>2</sup> or local gravity as specified. The RK tester is self-regulating with accuracy independent of the operator. The tester utilizes a virtually frictionless ceramic ball floating on a layer of air within a stainless steel cylinder. The RK tester features a quick-leveling system for field or lab setup. The unit may also be mounted on an optional tripod for more convenient setup. The tester may be operated with the cover opened or closed. Weights are located in foam-protective slots in the case.



**AMETEK**<sup>®</sup>  
CALIBRATION INSTRUMENTS



## FEATURES

The following are some of the features and characteristics inherent to the AMETEK RK deadweight tester.

### Floating Ball

While in operation, the RK tester's ball and weights float freely, supported only by a thin film of air which is virtually frictionless. This eliminates the necessity to rotate the weights during testing and allows the user to concentrate on the instrument calibration.

### Self-Regulating

The instrument's built-in flow regulator automatically adjusts the input air flow to maintain the ball and weights in a float position. The regulator also compensates for variations in pressure from the air supply. These features eliminate the necessity of having to continually adjust the supply during the test and provides for an easy up and down scale calibration.

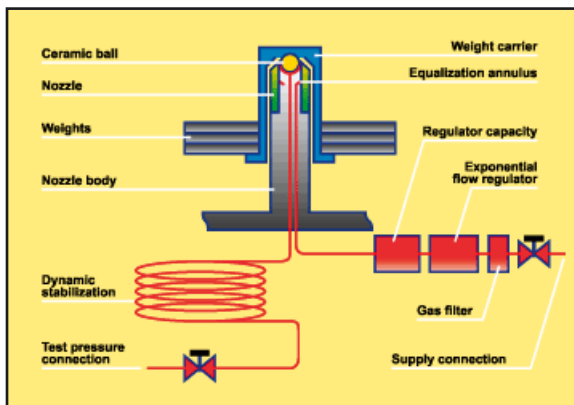

### Overhung weight carriers

Another feature of the RK deadweight tester is the way that the weights are positioned on the carrier. M&G utilizes an overhung weight carrier design. This design employs a tube carrier that is positioned over the column and onto the ceramic ball. The center of gravity for the stack of weights is lowered, reducing side thrust and friction; which lengthens the life of the ball/nozzle and carrier. This also improves measurement accuracy.

### Closed Cover Operation

The RK tester is designed to operate with the cover closed, thus eliminating the effects of wind during field operation.\*



### Rugged Ceramic Measuring Ball

The floating ball is manufactured from aluminum oxide ceramic - a material with near-diamond hardness. The ball, unlike steel and carbide pistons, may be dropped on hard surfaces without damage.

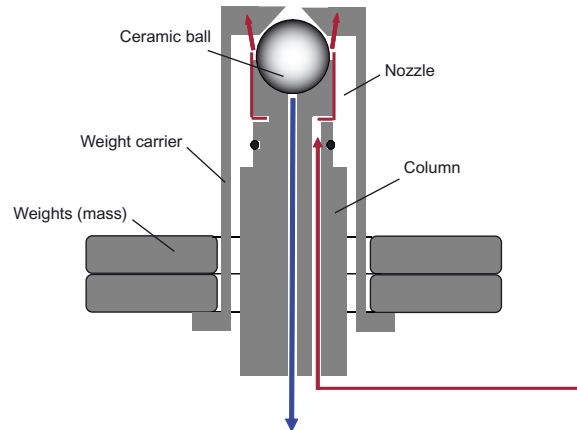

### Ball Valves

AMETEK floating ball testers, such as the RK tester, incorporate multi-position ball valves for both the inlet and outlet valve connections. These ensure trouble free operation that is both fast and efficient.

### Easy Leveling

AMETEK floating ball testers incorporate a bulls-eye level for reference when preparing the unit for use. The tester also employs a 3-leg leveling system which is more convenient and is superior to a 4-leg system.

### Quick Setup and Operation

The setup for the RK tester is completed by simply connecting two tubes, - one for the supply and one for the unit-under-test, leveling the RK, and adding the appropriate weights. Operation is fast and efficient with no valves to adjust and no regulation needed between set points. Pressure regulators are not required if the air supply is within the tester's operational requirements.

### Non-Contaminating Test Fluid

The instrument's test fluid is Nitrogen or instrument quality air complying with the ISA Standard S7.3. This fluid is non-contaminating to virtually all processes, thus eliminating the need to clean instruments after calibration and before use.

### Designed for field or lab use

The RK tester is designed for precision and is accurate enough for lab use. However, the construction is rugged enough to allow for reliable field operation as well. The instrument includes a built-in tripod mount. A tripod may be ordered separately.

### Small incremental weight sets

Small incremental weight sets are available to provide fractional output pressures. These are available for the RK deadweight tester in psi, bar, kPa, kg/cm<sup>2</sup>, inH<sub>2</sub>O and cmH<sub>2</sub>O.

\* Use of the large diameter weights is not possible with the cover closed.



## FUNCTIONAL SPECIFICATIONS

Model: ..... RK  
 Type:..... Pneumatic, ball type  
 Pressure range: . to 2,000 kPa / 300 psi (model dependent)  
 Accuracy (12 months): .....to ±0.015% rdg  
 Repeatability:.....±0.005% rdg  
 Temperature coefficient: ±0.00167% of rdg/°C (@ on 23 °C)  
 Increments (low - min):..... 1 psi, 0.01 kg/cm<sup>2</sup>, 0.01 bar,  
 ..... 1 kPa, 4 inH<sub>2</sub>O, 10 cmH<sub>2</sub>O, 1 inHg  
 Increments (small): Small incremental weight sets available  
 Gravity: .....9.80665 m/s<sup>2</sup> (international standard)  
 .....or Local gravity (specify when ordering)  
 Water column temp ref: ..... 20°C (ISA) (standard)  
 ..... or 60°F (AGA) (optional) (specify when ordering)  
 Weight sets:.....Single (as ordered)  
 Pressure source: .....Nitrogen or instrument/shop air  
 .....(ISA quality standard 7.3)  
 Supply pressure (max): .....31 bar / 450 psi  
 Supply pressure (min): .....2.1 bar / 30 psi  
 ..... or 150% of desired output pressure  
 Flow rate:..... 28 slh at 1 kPa/1 scfh at 0,15 psi output  
 ..... 1700 slh at 2000 kPa/60 scfh at 300 psi output  
 Test connections:..... 1/8" NPT  
 Weight material: .....Stainless steel and  
 .....aluminum (small incremental weights)  
 Ball material:.....Ceramic  
 Engineering units:..... psi, kg/cm<sup>2</sup>, bar, kPa,  
 ..... inH<sub>2</sub>O, cmH<sub>2</sub>O, inHg  
 Cases: ..... 1 or 2 (model dependent)

## PHYSICAL SPECIFICATIONS

Connections: ..... 1/4 in NPT female  
 Weight:  
 Tester only..... 8.2 - 14.3 kg / 18 to 31.5 lbs  
 Weights ..... 8.0 - 30 kg / 17.5 to 61.5 lbs  
 Shipping dimensions (L x W xH):  
 Tester .....38.1 x 24.1 x 20.3 cm / 15.0 x 9.5 x 8.0 in  
 Weights .....21.6 x 30.5 x 29.2 cm / 8.5 x 12.0 x 11.5 in  
 Configuration:..... Pneumatic deadweight  
 Delivery:.....Tester base, weight set, manual,  
 ..... and NIST traceable certification

## General Process Information for Calibrated Parts

- Local gravity values must be specified by customer in gals, cm/s<sup>2</sup> or m/s<sup>2</sup> .
- Include serial number, accuracy, gravity, and model number of deadweight tester when ordering weight sets or calibrated parts.
- Masses for weights ordered separately, including tolerance, must be supplied by customer; unless combined with tester on same order.
- Calibrated parts may be made to archival data if requested on the purchase order.
- Calibrated parts are certified for physical dimension only (mass or area) and not for accuracy unless ordered with a new tester or the tester is returned for proper calibration of parts.
- RK weight set changes and additions require a matching weight carrier and/or conversion ring for the proper incremental output values.

## Certification of Accuracy and Traceability

A Certification of Accuracy and Traceability to NIST is included with every AMETEK floating ball-type deadweight tester. An optional Certification of Accuracy with area, mass and intrinsic correction factors is available.



Notes: For ±0.015% testers, ±0.025% accuracy below 30" H<sub>2</sub>O, 1 psi, 7kPa, 100 cm H<sub>2</sub>O or 0.07 bar. Gravity 9.80665 m/s<sup>2</sup> or user's local gravity when specified. H<sub>2</sub>O (water column) models are calibrated to water at 20°C (68°F) but can be calibrated to water at 60°F.

Notes: Deadweight tester and deadweight gauge accuracy is expressed as "Percent of Indicated Pressure". A 1,000 psi tester with an accuracy of ±0.01% of indicated pressure will have an allowable error of 0.1 psi at 10 psi, ±0.1 psi at 100 psi and ±1.0 psi at 1,000 psi. Generally, deadweight testers are used only in the upper 90% of the range.

## ORDERING INFORMATION

Model	Certified Range	Increment	W/C and Ball Output
RK-50	1 to 51 psi	1 psi	1 psi
RK-100	1 to 101 psi	1 psi	1 psi
RK-200	1 to 201 psi	1 psi	1 psi
RK-300	1 to 301 psi	1 psi	1 psi
RK-4M	0.01 to 4 kg/cm <sup>2</sup>	0.01 kg/cm <sup>2</sup>	0.01 kg/cm <sup>2</sup>
RK-8M	0.01 to 8 kg/cm <sup>2</sup>	0.01 kg/cm <sup>2</sup>	0.01 and 0.02 kg/cm <sup>2</sup>
RK-20M	0.01 to 20 kg/cm <sup>2</sup>	0.01 kg/cm <sup>2</sup>	0.01 and 0.02 kg/cm <sup>2</sup>
RK-2B	0.01 to 2 bar	0.01 bar	0.01 bar
RK-4B	0.01 to 4 bar	0.01 bar	0.01 bar
RK-8B	0.01 to 8 bar	0.01 bar	0.01 and 0.02 bar
RK-12B	0.01 to 12 bar	0.01 bar	0.01 and 0.02 bar
RK-20B	0.01 to 20 bar	0.01 bar	0.01 and 0.02 bar
RK-200N	1 to 211 kPa	1 kPa	1 kPa
RK-400N	1 to 411 kPa	1 kPa	1 kPa
RK-800N	1 to 811 kPa	1 kPa	1 and 2 kPa
RK-1200N	1 to 1,211 kPa	1 kPa	1 and 2 kPa
RK-2000N	1 to 2,011 kPa	1 kPa	1 and 2 kPa
RK-100WC	4 to 104 inH <sub>2</sub> O	1 inH <sub>2</sub> O	4 inH <sub>2</sub> O
RK-300WC	4 to 314 inH <sub>2</sub> O	1 inH <sub>2</sub> O	4 inH <sub>2</sub> O
RK-600WC	4 to 614 inH <sub>2</sub> O	1 inH <sub>2</sub> O	4 inH <sub>2</sub> O
RK-1100WC	4 to 1,114 inH <sub>2</sub> O	1 inH <sub>2</sub> O	4 inH <sub>2</sub> O
RK-1600WC	4 to 1,614 inH <sub>2</sub> O	1 inH <sub>2</sub> O	4 inH <sub>2</sub> O
RK-500CM	10 to 510 cmH <sub>2</sub> O	10 cmH <sub>2</sub> O	10 cmH <sub>2</sub> O
RK-1000CM	10 to 1,010 cmH <sub>2</sub> O	10 cmH <sub>2</sub> O	10 cmH <sub>2</sub> O
RK-2000CM	10 to 2,010 cmH <sub>2</sub> O	10 cmH <sub>2</sub> O	10 cmH <sub>2</sub> O
RK-3000CM	10 to 3,010 cmH <sub>2</sub> O	10 cmH <sub>2</sub> O	10 cmH <sub>2</sub> O
RK-4000CM	10 to 4,010 cmH <sub>2</sub> O	10 cmH <sub>2</sub> O	10 cmH <sub>2</sub> O
RK-100H	1 to 112 inHg	0.1 inHg	1 inHg

### Calibration Options

Model Suffix	Accuracy	Gravity	Data
NONE	±0.050% rdg (standard)	Standard or local gravity (specify)	None
-1B	±0.025% rdg (optional)	Standard or local gravity (specify)	None
-1A	±0.015% rdg (optional)	Standard or local gravity (specify)	None
/C	±0.050% rdg (standard)	Standard or local gravity (specify)	Yes
-1B/C	±0.025% rdg (optional)	Standard or local gravity (specify)	Yes
-1A/C	±0.015% rdg (optional)	Standard or local gravity (specify)	Yes

### Accessories

Order no.	Description
RWS-.1WC	Aluminum weight set, Converts 1" H <sub>2</sub> O units to 0.1" H <sub>2</sub> O increments
RWS-.1	Aluminum weight set, Converts 1 psi units to 0.1 psi increments
RWS-.1KPA	Aluminum weight set, Converts 1 kPa units to 0.1 kPa increments
RWS-.1CM	Aluminum weight set, Converts 10 cm H <sub>2</sub> O units to 1 cm H <sub>2</sub> O increments
RWS-.001B	Aluminum weight set, Converts 0.01 bar units to 0.001 bar increments
RWS-.001M	Aluminum weight set, Converts 0.01 kg/cm <sup>2</sup> units to 0.001 kg/cm <sup>2</sup>
K-1562	Tripod
1GT-99	Gauge pointer puller set
	Small incremental weight sets available in psi, bar, kPa, kg/cm <sup>2</sup> , inH <sub>2</sub> O and cmH <sub>2</sub> O

**AMETEK**<sup>®</sup>  
CALIBRATION INSTRUMENTS

Pub code SS-CP-2120-US Issue 00901

<http://www.instrumentation2000.com>

4



**AMETEK Calibration Instruments**  
is one of the world's leading manufacturers and developers of calibration instruments for temperature, pressure and process signals as well as for temperature sensors both from a commercial and a technological point of view.

**JOFRA Temperature Instruments**  
Portable precision thermometers. Dry-block and liquid bath calibrators: 4 series, with more than 25 models and temperature ranges from -90° to 1205°C / -130° to 2200°F. All featuring speed, portability, accuracy and advanced documenting functions with JOFRACAL calibration software.

**JOFRA Pressure Instruments**  
Convenient electronic systems ranging from -1 to 1000 bar (25 inHg to 14,500 psi) - multiple choices of pressure ranges, pumps and accuracies, fully temperature-compensated for problem-free and accurate field use.

**JOFRA Signal Instruments**  
Process signal measurement and simulation for easy control loop calibration and measurement tasks - from handheld field instruments to laboratory reference level bench top instruments.

**JOFRA / JF Marine Instruments**  
A complete range of calibration equipment for temperature, pressure and signal, approved for marine use.

**FP Temperature Sensors**  
A complete range of temperature sensors for industrial and marine use.

**M&G Pressure Testers**  
Pneumatic floating-ball or hydraulic piston dead weight testers with accuracies to 0.015% of reading.

**M&G Pumps**  
Pressure generators from small pneumatic "bicycle" style pumps to hydraulic pumps generating up to 1,000 bar (15,000 psi).

*...because calibration is  
a matter of confidence*

**Contact:**  
Industrial Process Measurement, Inc.  
3910 Park Avenue, Unit 7  
Edison, NJ 08820  
732-632-6400  
support@instrumentation2000.com  
<http://www.instrumentation2000.com>