

**Pressure Range**

50 to 10,000 kPa (10 to 1500 psi)

Accuracyto $\pm 0.025\%$ of Indicated reading**Repeatability** $\pm 0.005\%$ of indicated reading**Available units**psi, kg/cm², bar, kPa**Special Calibrations/Local Gravity**

HK testers are supplied standard with masses calibrated to International Standard gravity of 9.80665 m/s².

Local gravity calibration is available on all models.

High Pressure Pneumatic Standard

The HK is a high pressure pneumatic alternative to the available hydraulic standards. This series allows for self-regulating calibrations at high pressures without leaving a hydraulic residue in the UUT.

Exceptional Performance and Safety Built-In

- Floating Ball Operation
- Self-Regulating
- Rugged Ceramic Measuring Ball
- Overhung Weight Carrier
- Non-Contaminating Test Fluid
- Ball Valves for Inlet and Outlet
- Interchangeable Weights
- Prefill Supplied for Quick Filling
- Large Static
- Output Volumes
- NIST Traceable

ISO 9001 Manufacturer

Model HK

Pneumatic Deadweight Tester**PRODUCT DESCRIPTION**

The AMETEK HK Pneumatic Deadweight Tester is a primary standard used to calibrate pressure and differential pressure gauges, transmitters, transducers, recorders and controllers, which can provide a reference pressure in process control applications.

Self-regulating pressure standard

The AMETEK HK Pneumatic Deadweight Tester is a primary standard that produces a pressure by applying force (weight set) over area (the ceramic ball and nozzle). The HK tester is NIST traceable and accurate to $\pm 0.015\%$ using stainless steel weights calibrated to International standard gravity at 9.80665 m/s² or local gravity as specified.

The HK tester is self-regulating with accuracy independent of the operator. The tester utilizes a virtually frictionless ceramic ball floating on a layer of air within a stainless steel cylinder.

The HK tester features a quick-leveling system for lab setup. The unit may also be mounted on an optional tripod for more convenient setup. Weights are located in foam-protective slots in the case.



AMETEK[®]
CALIBRATION INSTRUMENTS



FEATURES

The following are some of the features and characteristics inherent to the AMETEK HK deadweight tester.

Floating Ball

While in operation, the HK tester's ball and weights float freely, supported only by a thin film of air which is virtually frictionless. This eliminates the necessity to rotate the weights during testing and allows the user to concentrate on the instrument calibration.

Self-Regulating

The instrument's built-in flow regulator automatically adjusts the input air flow to maintain the ball and weights in a float position. The regulator also compensates for variations in pressure from the air supply. These features eliminate the necessity of having to continually adjust the supply during the test and provides for an easy up and down scale calibration.

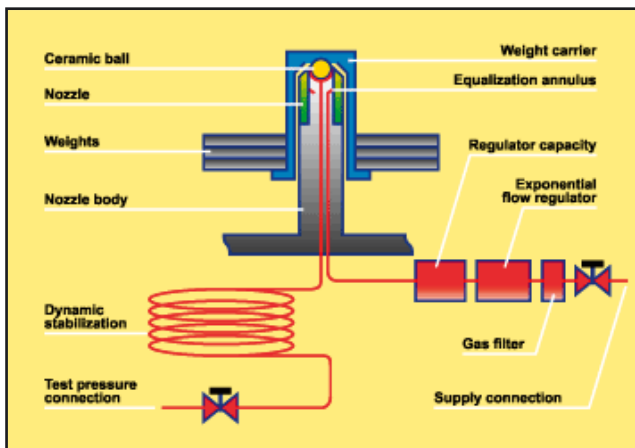

Overhung weight carriers

Another feature of the HK deadweight tester is the way that the weights are positioned on the carrier. M&G utilizes an overhung weight carrier design. This design employs a tube carrier that is positioned over the column and onto the ceramic ball. The center of gravity for the stack of weights is lowered, reducing side thrust and friction; which lengthens the life of the ball/nozzle and carrier. This also improves measurement accuracy.



Rugged Ceramic Measuring Ball

The floating ball is manufactured from aluminum oxide ceramic - a material with near-diamond hardness. The ball, unlike steel and carbide pistons, may be dropped on hard surfaces without damage.

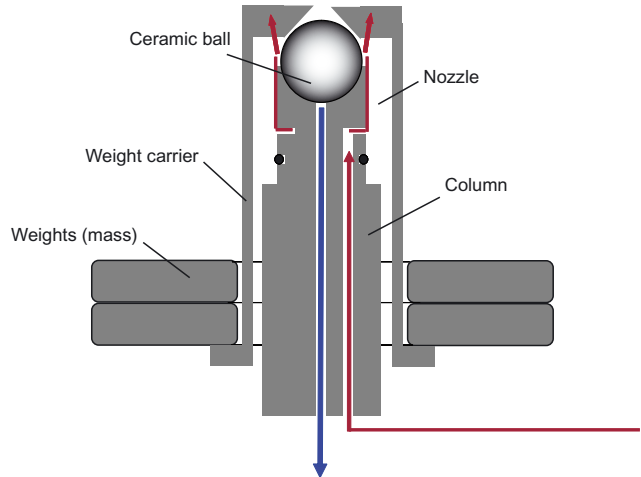

Quick Setup and Operation

The setup for the HK tester is completed by simply connecting two tubes, - one for the supply and one for the unit-under-test, leveling the HK, and adding the appropriate weights. Operation is fast and efficient with no valves to adjust and no regulation needed between set points. Pressure regulators are not required if the air supply is within the tester's operational requirements.

Non-Contaminating Test Fluid

The instrument's test fluid is Nitrogen or instrument quality air complying with the ISA Standard S7.3. This fluid is non-contaminating to virtually all processes, thus eliminating the need to clean instruments after calibration and before use.

Designed for lab use

The HK tester is designed for precision and is accurate enough for lab use. However, the construction is rugged enough to allow for reliable field operation as well.

Ball Valves

AMETEK floating ball testers, such as the HK tester, incorporate multi-position ball valves for both the inlet and outlet valve connections. These ensure trouble free operation that is both fast and efficient.

Easy Leveling

AMETEK floating ball testers incorporate a bulls-eye level for reference when preparing the unit for use. The tester also employs a 3-leg leveling system which is more convenient and is superior to a 4-leg system.



FUNCTIONAL SPECIFICATIONS

Model: HK
 Type:..... Pneumatic, ball type
 Pressure range:to 10,000 kPa / 1,500 psi
(model dependent)
 Accuracy (12 months):to ±0.025% rdg
 Repeatability:..... ±0.005% rdg
 Temperature coefficient:±0.00167% of rdg/°C (@ 23°C)
 Increments (low - min):..... 1 psi, 0.1 kg/cm²,
0.1 bar, 5 kPa, 2 inHg
 Gravity:9.80665 m/s² (international standard)
or Local gravity (specify when ordering)
 Weight sets:..... Single (as ordered)
 Pressure source:Nitrogen or instrument/shop air
(ISA quality standard 7.3)
 Supply pressure (max):
 Models to 70 bar (1,000 psi): 100 bar / 1,500 psi
 Models to 100 bar (1,500 psi): 150 bar / 2,250 psi
 Supply pressure (min):10.3 bar / 150 psi
 or 150% of desired output pressure
 Flow rate:..... 85 slh at 100 kPa/3 scfh at 10 psi output
 2800 slh at 10,000 kPa/100 scfh at 1500 psi output
 Test connections:..... 7/16-20 37° conical 1/4" OD
 Weight material: Stainless steel
 Ball material:..... Ceramic
 Engineering units:.....psi, kg/cm², bar, kPa, inHg

PHYSICAL SPECIFICATIONS

Connections: 0.25 in OD tubing, 7/16-20, 37° AN angle
 Weight:
 Tester Only 8.2 - 14.3 kg / 18 to 31.5 lbs
 Weights 8.0 - 30.0 kg / 17.5 to 61.5 lbs
 Shipping dimensions (L x W x H):
 Tester40.6 x 40.6 x 40.6 cm / 16.0 x 16.0 x 16.0 in
 Weight Set Storage Case
5.1 x 30.5 x 30.5 cm / 2.0 x 12.0 x 12.0 in
 Configuration:..... Pneumatic deadweight
 Delivery:..... Tester base, weight set, manual,
 and NIST traceable certification

General Process Information for Calibrated Parts

- Local gravity values must be specified by customer in gals, cm/s² or m/s².
- Include serial number, accuracy, gravity, and model number of deadweight tester when ordering weight sets or calibrated parts.
- Masses for weights ordered separately, including tolerance, must be supplied by customer; unless combined with tester on same order.
- Calibrated parts may be made to archival data if requested on the purchase order.
- Calibrated parts are certified for physical dimension only (mass or area) and not for accuracy unless ordered with a new tester or the tester is returned for proper calibration of parts.
- HK weight set changes and additions require a matching weight carrier for the proper incremental output values.

Certification of Accuracy and Traceability

A Certification of Accuracy and Traceability to NIST is included with every AMETEK floating ball-type deadweight tester. An optional Certification of Accuracy with area, mass and intrinsic correction factors is available.

Notes: For ±0.025% testers, ±0.025% accuracy below 30" H₂O, 1 psi, 7 kPa, 100 cm H₂O or 0.07 Bar. Gravity 9.80665 m/s² or user's local gravity when specified. H₂O (water column) models are calibrated to water at 20°C (68°F) but can be calibrated to water at 60°F.

Notes: Deadweight tester and deadweight gauge accuracy is expressed as "Percent of Indicated Pressure". A 1,000 psi tester with an accuracy of +0.01% of indicated pressure will have an allowable error of 0.1 psi at 10 psi, +0.1 psi at 100 psi and +1.0 psi at 1,000 psi. Generally, deadweight testers are used only in the upper 90% of the range.

ORDERING INFORMATION

Model	Certified Range	Increment	W/C and Ball Output
HK-500	10 to 500 psi	1 psi	10 psi
HK-700	10 to 700 psi	1 psi	10 psi
HK-1000	10 to 1,000 psi	1 psi	10 psi
HK-1500	10 to 1,500 psi	1 psi	10 psi
HK-40M	0.5 to 40 kg/cm ²	0.1 kg/cm ²	0.5 kg/cm ²
HK-50M	0.5 to 50 kg/cm ²	0.1 kg/cm ²	0.5 kg/cm ²
HK-70M	0.5 to 70 kg/cm ²	0.1 kg/cm ²	0.5 kg/cm ²
HK-100M	0.5 to 100 kg/cm ²	0.1 kg/cm ²	0.5 kg/cm ²
HK-40B	0.5 to 40 bar	0.1 bar	0.5 bar
HK-50B	0.5 to 50 bar	0.1 bar	0.5 bar
HK-70B	0.5 to 70 bar	0.1 bar	0.5 bar
HK-100B.1	0.5 to 100 bar	0.1 bar	0.5 bar
HK-4000N	50 to 4,000 kPa	10 kPa	50 kPa
HK-5000N	50 to 5,000 kPa	10 kPa	50 kPa
HK-7000N	50 to 7,000 kPa	10 kPa	50 kPa
HK-10000N	50 to 10,000 kPa	10 kPa	50 kPa

Calibration Options

Model Suffix	Accuracy	Gravity	Data
NONE	±0.025% rdg (standard)	Standard or local gravity (specify)	None
/C	±0.025% rdg (standard)	Standard or local gravity (specify)	Yes

Accessories

Order no.	Description
K-1454	Soft cover



AMETEK Calibration Instruments
is one of the world's leading manufacturers and developers of calibration instruments for temperature, pressure and process signals as well as for temperature sensors both from a commercial and a technological point of view.

JOFRA Temperature Instruments
Portable precision thermometers. Dry-block and liquid bath calibrators: 4 series, with more than 25 models and temperature ranges from -90° to 1205°C / -130° to 2200°F. All featuring speed, portability, accuracy and advanced documenting functions with JOFRACAL calibration software.

JOFRA Pressure Instruments
Convenient electronic systems ranging from -1 to 1000 bar (25 inHg to 14,500 psi) - multiple choices of pressure ranges, pumps and accuracies, fully temperature-compensated for problem-free and accurate field use.

JOFRA Signal Instruments
Process signal measurement and simulation for easy control loop calibration and measurement tasks - from handheld field instruments to laboratory reference level bench top instruments.

JOFRA / JF Marine Instruments
A complete range of calibration equipment for temperature, pressure and signal, approved for marine use.

FP Temperature Sensors
A complete range of temperature sensors for industrial and marine use.

M&G Pressure Testers
Pneumatic floating-ball or hydraulic piston dead weight testers with accuracies to 0.015% of reading.

M&G Pumps
Pressure generators from small pneumatic "bicycle" style pumps to hydraulic pumps generating up to 1,000 bar (15,000 psi).

*...because calibration is
a matter of confidence*

AMETEK[®]
CALIBRATION INSTRUMENTS

Contact:
Industrial Process Measurement, Inc.
3910 Park Avenue, Unit 7
Edison, NJ 08820
732-632-6400
support@instrumentation2000.com
<http://www.instrumentation2000.com>